

SENTRY *Custom Graphics* LED Signs DCG Series



Architectural quality, open face Sentry Series die cast aluminum sign. Long Life, low energy LED light source illuminates a polycarbonate lens stenciled with your required custom legend.

Features

- Maintenance free LED light source with 25+ years life expectancy
- High intensity LED array provides exceptional energy efficiency with just 1 watt power consumption for both single and double face AC models. Battery backup models consume just 2.5 watts, .77 power factor
- Uniform vivid legend illumination available with Red, Green, Blue or White LED light source.
- Silver-White opaque stencil background is standard. Custom colors are available to order
- Spectrally matched Fluorescent diffuser for superior visual brightness and legend uniformity
- **Self-Diagnostic** Battery monitoring on all 'EM' models
- 4 Hour battery backup runtime with Premium long life high temperature fused nickel cadmium battery pack 120 or 277 VAC field selectable input with quick install push wire connectors
- Electronic control circuit applies **full wave**, low ripple current to each LED thereby optimizing life and light output. A diagnostic self compensating constant current charger circuit monitors the condition of the battery pack and indicates via a flashing LED when battery needs replacing
- Circuitry includes - Zero current LVCO, Brownout sensing & Line-Latch

Construction

- Two piece thick wall construction housing from heavy duty die cast aluminum alloy, removable front face with overlapping light seal
- Fine grain brushed aluminum trim standard. Other finishes available
- Wide selection of standard legends available, custom legends available to order
- Hidden knock out access points and universal pattern
- Low profile universal canopy with cast 3/4" nipple and locking nuts
- Optional recessing frame, polycarbonate face shield with tamper proof access screws, pendant & specialty mounts
- Remote capable
- 5 Year Warranty

SENTRY *Custom Graphics* LED Signs DCG Series

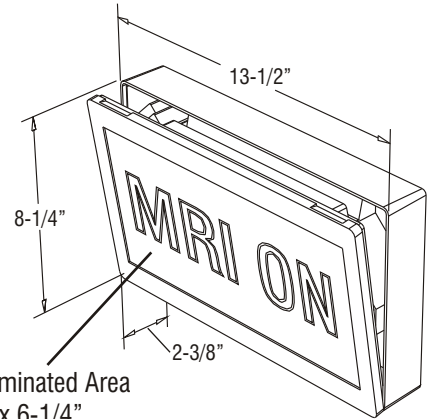
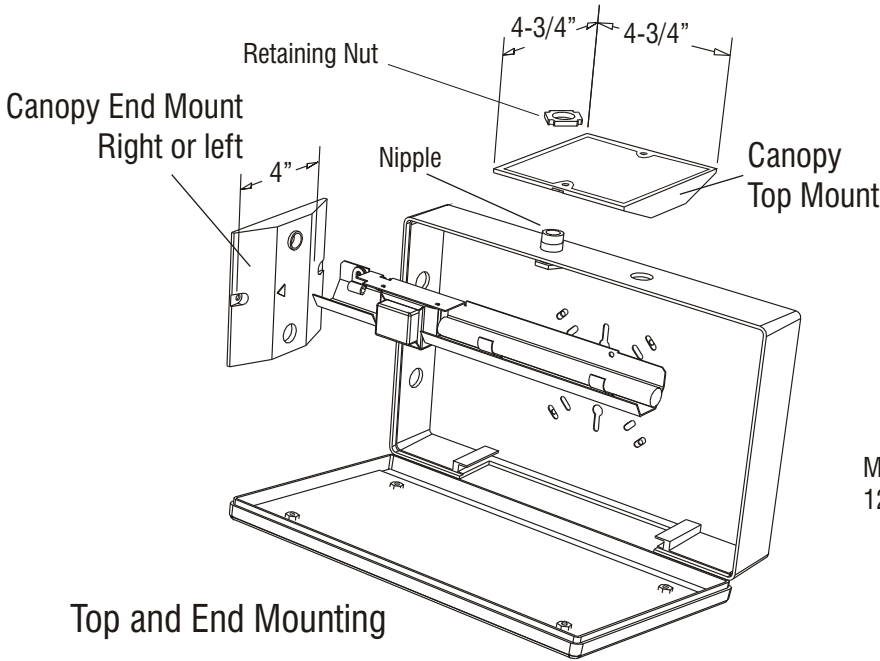

Opening the Unit

Note: Wire Guard available see data sheet 5.1

SENTRY *Custom Graphics* Ordering Guide

DCG - EM - 1 - AB - 1B - RD - BK - F

AC AC Only 120/277 VAC
EM Battery Backup

1 Single Face
2 Double Face
No. of Faces

AB Brushed Face, Black Body
BB All Black
WW All White
AA All Brushed Aluminum
AW Brushed Face, White Body
CC Custom Color
Body and Face Color

1B Back Mount, No Canopy
CN Canopy Mounting Kit
RE Recessing Frame (Includes 1B Mount)
PA 12" Swivel Pendant Mount
PB 24" Swivel Pendant Mount
PC 36" Swivel Pendant Mount
PD 48" Swivel Pendant Mount
Mounting

Options

F Flash in Emergency Mode (EM models only)
FZ F option including Buzzer
FA Fire Alarm Interface from 12 - 24 Volt (AC or DC) Normally Off Fire Alarm Signal (EM models only)
FB FA option including Buzzer
DK Two Circuit Input, 120 or 277 V (AC models only)
LL High/Low Level Master/Remote (AC and EM models - Remote is 1B mount w/recessing frame)
DL Damp Location
TP Tamperproof Screws
P1 1/8" Polycarbonate Shield (includes TP)
SD Self Test / Self Diagnostic

Background Color

W White
BK Black
C Custom (specify)

Illuminated Letter Color

RD Red
GN Green
BL Blue
W White
C Custom (specify)



3161 State Road
Bensalem, PA 19020
Tel: (800)872 0879
Fax: (215)244 4208
www.evenlite.com 09/07

Fixture Schedule	Project Name:	Approved By:
	Catalog No:	Type No: