

SENTRY INDUSTRIAL

LED Exit Signs CDI Series



The Sentry Industrial provides the quality performance and appearance of the standard Sentry series LED exit sign enhanced with a durable 1/8" thick polycarbonate security faceplate cover, tamper resistant access screws and where required, a Heavy Duty mounting canopy.

Lamps & Lighting

- Polycarbonate face shields provide impact resistance to the stencil face
- Tamper resistant hardware secures face shield and restricts access
- Maintenance free LED light source with 25+ years life expectancy
- High intensity LED array provides exceptional energy efficiency with just 1 watt power consumption for both single and double face AC models. Battery backup models consume just 2.5 watts, .77 power factor
- Vivid legend illumination approx. 4 times the minimum UL 924 requirement
- Injection molded internal cavity reflector provides ease of installation and maintenance together with perfectly Even legend illumination
- Spectrally matched fluorescent diffuser for superior visual brightness and uniformity
- **Self-Diagnostic** Battery monitoring on all 'EM' models
- 4 Hour battery backup runtime with premium long life, high temperature fused nickel cadmium battery pack
- 120 or 277 VAC field selectable input with quick install push-wire connectors
- Electronic control circuit applies **full wave**, low ripple current to each LED thereby optimizing life and light output. A diagnostic self-compensating constant current charger circuit monitors the condition of the battery pack and indicates via a flashing LED when battery needs replacing
- Circuitry includes - Zero current LVCO, Brownout sensing & Line-Latch

Construction

- Die cast aluminum housing with a minimum wall thickness of .08", and a 1/8" thick beveled edge polycarbonate security cover over each stencil face.
- Security cover and hinged faceplate is secured and locked with tamper resistant stainless steel screws
- Ceiling or end wall mounting installations are provided with an oversized canopy that enables more secure mounting with fixing points over a larger surface area. Canopy is attached to sign (field selectable mount) with two die cast 3/8" nipples and lock nuts and is suitable for conduit entry.
- Fine grain brushed aluminum stencil face standard. Other finishes available
- Full size 100' viewing distance field selectable Chevron indicators.
- Hidden knock out access points and universal pattern
- Remote Capable
- Tested, approved and listed by Underwriters Laboratories to UL 924
- 5 Year Warranty



SENTRY INDUSTRIAL

LED Exit Signs CDI Series

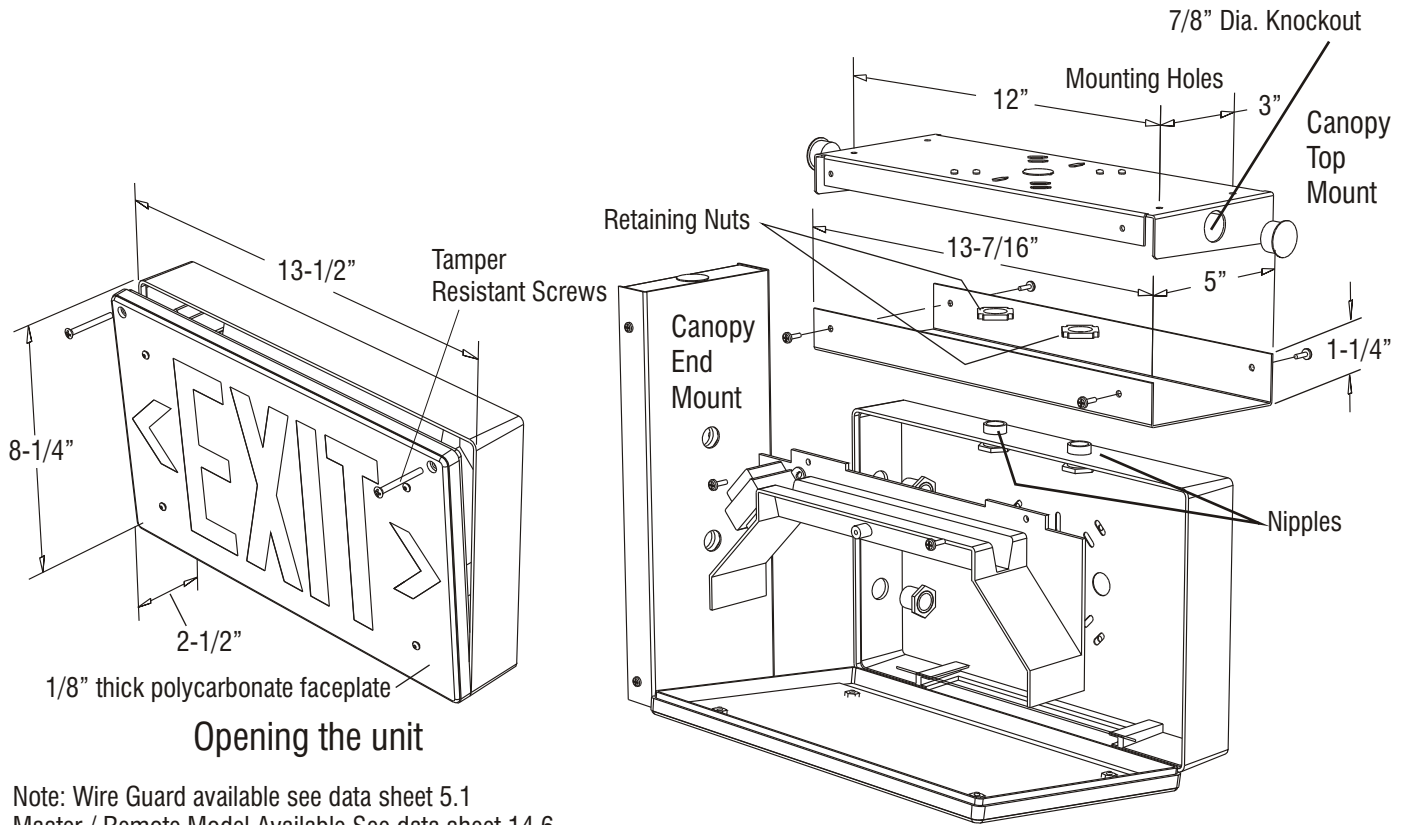

Opening the unit

Note: Wire Guard available see data sheet 5.1
Master / Remote Model Available See data sheet 14.6

Top and End Mounting
(Field Selectable)

SENTRY INDUSTRIAL Ordering Guide

CDI - EM - R - 1 - AB - CI - F

AC AC Only 120/277 VAC
EM Battery Backup

R Red
G Green
Letter Color

1 Single
2 Double
No. of Faces

AB Brushed Face, Black Body
BB All Black
WW All White
AA All Brushed Aluminum
AW Brushed Face, White Body
CC Custom Color
Body Color

Options

F Flash in Emergency Mode (EM models) or continuous Flash in AC models
FZ F option including Buzzer
FA Flash in AC and Emergency mode on 12-24V (AC or DC) normally off fire alarm signal. (Available for AC and EM models)
FB FA option including Buzzer
DK Two Circuit Input, 120 or 277 V (AC models)
DL Damp Location
PC2 1/4" Polycarbonate Faceplate
SD Self-Test / Self-Diagnostic
IR Infra-Red Remote Testing Receiver Option
TLRT Infra-Red Remote Hand Held Transmitter (order separately)

Mounting

1B Single Face, Back Mount Only
CI Industrial Canopy
RE Recessing Frame
Includes 1/8" Polycarbonate Shield and Tamper Proof Screws



3161 State Road
Bensalem, PA 19020
Tel: (800)872 0879
Fax: (215)244 4208
www.evenlite.com 10/07

Fixture
Schedule

Project Name:	Approved By:
Catalog No:	Type No: