

SENTRY ^{Recessed}

Die Cast Aluminum LED Exit Signs



Providing the quality appearance of the Sentry die cast aluminum sign, the Sentry Recessed is mounted flush into the wall to provide minimal intrusion. Together with a 1/8" polycarbonate wall cover, the Sentry Recessed is ideal for low level installations.

Features

- Ultra low profile extending only 1/8" from a wall surface
- Maintenance free LED light source with 25+ years life expectancy
- High intensity LED array provides exceptional energy efficiency with just one watt power consumption for AC models. Battery backup models consume just 2.5 watts, .77 power factor
- Vivid legend illumination approx. 4 times the minimum UL 924 requirement
- Injection molded internal cavity reflector provides ease of installation and maintenance together with perfectly Even legend illumination
- Spectrally matched fluorescent diffuser for superior visual brightness and uniformity
- **Self-Diagnostic** Battery monitoring on all 'EM' models. 4 Hour battery backup runtime with premium long life, high temperature fused nickel cadmium battery pack. 120 or 277 VAC field selectable input with quick install push-wire connectors
- Electronic control circuit applies **full wave**, low ripple current to each LED thereby optimizing life and light output. A diagnostic self-compensating constant current charger circuit monitors the condition of the battery pack and indicates via a flashing LED when battery needs replacing
- Circuitry includes - Zero current LVCO, Brownout sensing & Line-Latch

Construction

- Formed steel recessing pan with plaster trim. Quick fit in old or new work installations
- 1/8" thick polycarbonate window trim with beveled edges withstands high impact while providing a clean finished appearance
- Window trim area finished in white. The window mounts to the recessing pan with supplied tamper resistant hardware
- Sentry Housing has a two piece, thick wall construction from heavy duty die cast aluminum alloy, with a removable front stencil face with overlapping light seal.
- Fine grain brushed aluminum stencil face standard. Other finishes available
- Full size 100' viewing distance field selectable Chevron indicators.
- Hidden knock out access points and universal pattern
- Remote capable
- Tested, approved and listed by Underwriters Laboratories to UL 924
- 5 Year Warranty



SENTRY ^{Recessed} Die Cast Aluminum LED Exit Signs

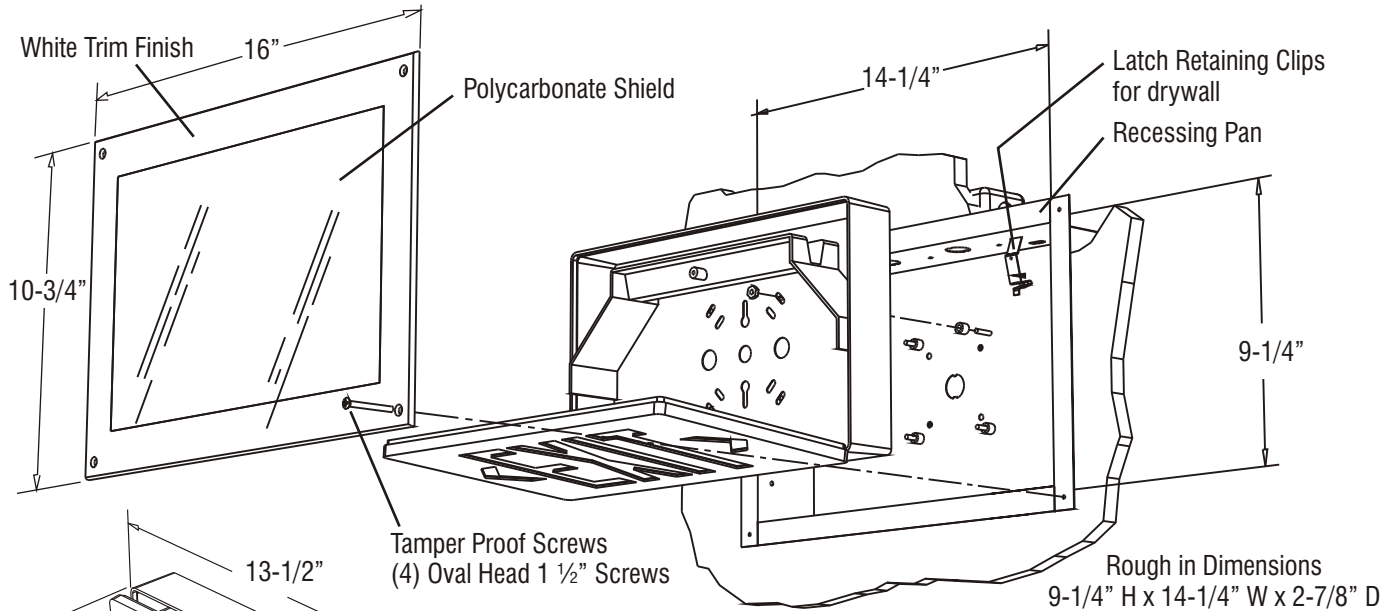

TYPICAL INSTALLATION

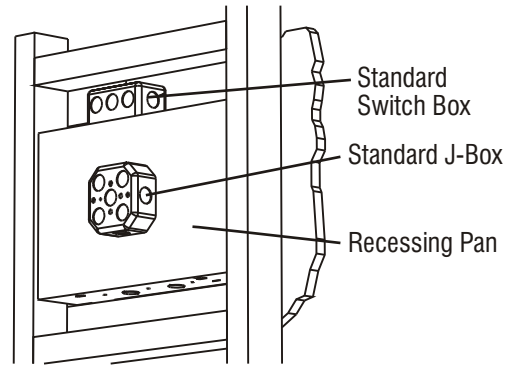
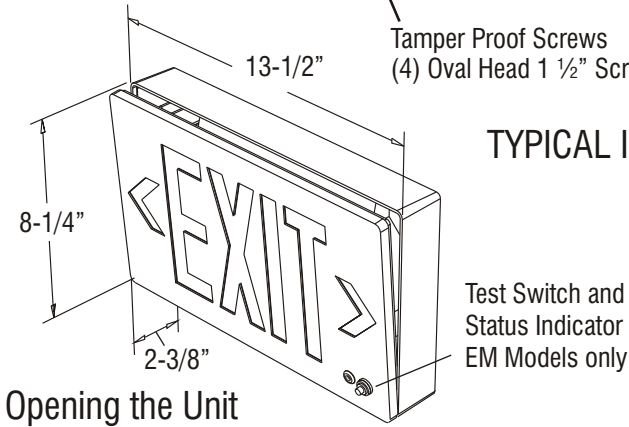

Typical Wall Mount (rear view)

SENTRY ^{Recessed} Ordering Guide

CCDS - EM - R - 1 - AB - REC - F

AC AC Only 120/277 VAC
EM Battery Backup

R Red
G Green
Letter Color

1 Single Face Only
No. Of Faces

AB Brushed Face, Black Body
BB All Black
WW All White
CC Custom Color
Body Color

REC Recessing Frame, Back Mount
Mounting

Options

F Flash in Emergency Mode (EM models) or continuous Flash in AC models

FZ F option including Buzzer

FA Flash in AC and Emergency mode on 12-24V (AC or DC) normally off fire alarm signal. (Available for AC and EM models)

FB FA option including Buzzer

DK Two Circuit Input, 120 or 277 V (AC models)

DL Damp Location

SD Self-Test / Self-Diagnostic

IR Infra-Red Remote Testing Receiver Option

TLRT Infra-Red Remote Hand Held Transmitter (order separately)



3161 State Road
 Bensalem, PA 19020
 Tel: (800)872 0879
 Fax: (215)244 4208
 www.evenlite.com 10/07

Fixture Schedule

Project Name:	Approved By:
Catalog No:	Type No: