

# Weatherlite Wet Location

## Architectural Emergency Egress Light

### WEATHERLITE - Wet Location Architectural Emergency Egress Light

The Weatherlite emergency light provides an attractive solution to applications that require low profile egress emergency lighting with rugged durability and good looks. Constructed of die-cast aluminum with a polycarbonate refractor and finished in epoxy powder coat, the Weatherlite is gasket sealed ready for use in both outdoor and indoor applications.

Weatherlite features an optional decorative lighting effect by providing internally mounted color LED's that cause both clear lenses to glow the chosen color. The feature is activated by a dusk-to-dawn photocell and consumes less than 1 watt.

Weatherlite features Self-Test / Self-Diagnostics that continually monitor the Charger, Transfer Circuit, Battery, Power Supply and Lamps. Any troubles are indicated via a flashing fault code from a bi-color LED. Self-testing by discharge occurs for one minute each 28 days, 30 minutes on the sixth month and a full 90 minutes on the twelfth month, thereby ensuring the user can maintain optimum performance reliability.



### Features

- Wet location listed for indoor or outdoor applications 0 deg to 50 deg C
- Optional Cold temperature package for -20 deg to 50 deg C applications
- Rugged die-cast aluminum construction
- Durable powder coat finish available in Bronze, White, Black and Aluminum
- Snap fit assembly with vandal resistant latch clips; no visible hardware  
Gasket sealed to suit universal junction boxes.
- Conduit entry provided on top of unit
- Available as a 6 volt DC remote fixture
- UV stabilized polycarbonate refractor resists yellowing and provides uniform distribution
- Two 6 Watt High Output Xenon lamps for superior illumination
- Optional decorative colored night light
- Integral push-to-test switch

### Electronics

- Self Test / Self diagnostic circuit is provided as standard thereby reducing manual testing obligations
- Easily visible Bi-Color LED diagnostic indicator
- Automated 28 day self test checks lamp, battery, electronic circuitry over a short one minute test. Extended 30 and 90 minute emergency duration tests are automatically conducted.
- Premium long life high temperature rated Nickel Cadmium battery.
- Sealed externally accessible test switch for manual momentary test operation
- Field selectable 120 or 277 VAC input
- Brownout sensing assures emergency illumination during periods of low line voltage.
- Self-compensating solid state Constant Current Charger provides extended float life and rapid recharge
- Zero current LVCO ensures positive charge acceptance following an extended discharge
- 3 Year limited warranty
- Listed to UL 924 Damp and Wet locations



# Weatherlite Wet Location Architectural Emergency Egress Light

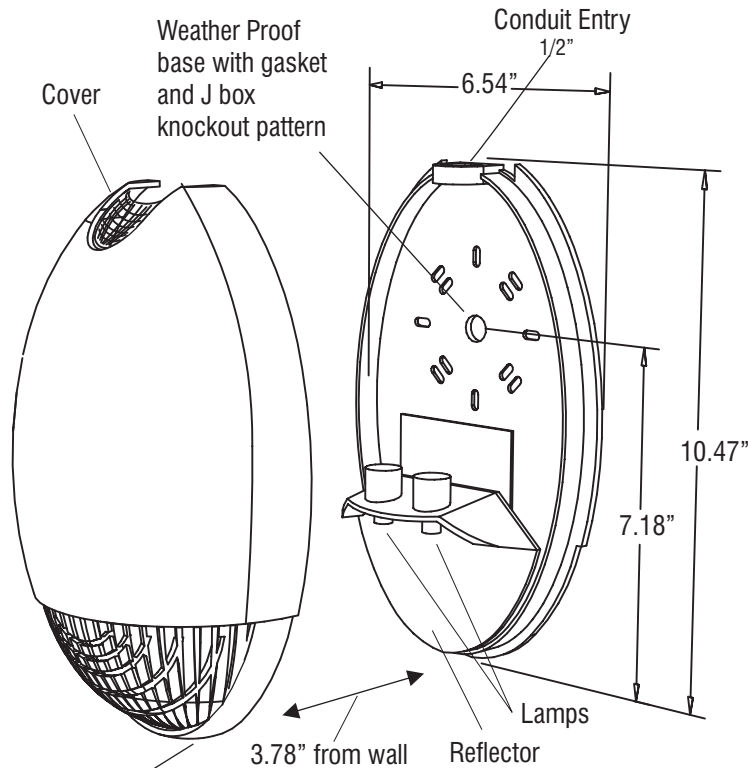

Horizontal Lines of Isofootcandles  
Mounting Height 8 feet - Single Unit

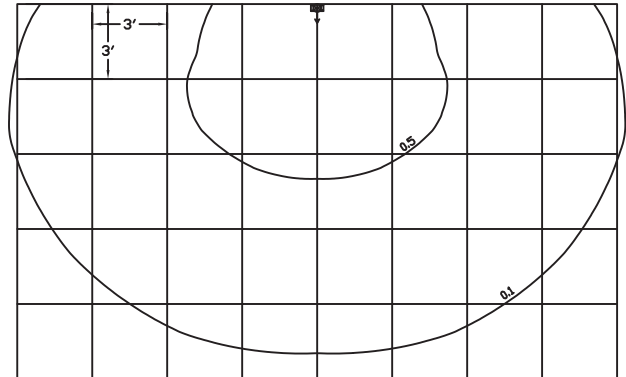

Push to Test /  
Diagnostic Indicator  
Grn

### Included Self Diagnostic

- |   |                            |  |
|---|----------------------------|--|
| <b>Diagnostic Indicator / Test Switch</b> | ● Ready                    | <b>Manual Testing</b><br>Press button once - 1 minute test<br>Press button twice - 5 minute test<br>Press button 3 times - 30 minute test<br>Press button 4 times - 90 minute test |
|   | ● In Test                  |  |
|   | ● Battery Circuit Fault    |  |
|   | ● Battery Capacity Failure |  |
|   | ● Charger Failure          |  |
|   | ● Transformer Fault        |  |
|   | ● Lamp Failure             |  |
|   | ● Lamp Failure             |  |

Full self-test, self-diagnostic system is standard in every unit, performs a monthly, semi-annual, and annual full system test as well as continuously monitoring all functions to ensure reliability

## Weatherlite Ordering Guide



**Model No.**  
**WL6** Self-contained Battery Back up  
 6 volt DC  
**WLR** 12 watt Remote only  
 (2-6 Watt Lamps)

**Housing Color**  
**BZ** - Bronze  
**WH** - White  
**BK** - Black  
**AL** - Brushed Aluminum

**Options**  
**NLGN** - Green Decorative LED Night Light  
**NLAM** - Amber Decorative LED Night Light  
**NLWT** - White Decorative LED Night Light  
**NLBL** - Blue Decorative LED Night Light  
 Note: Decorative LED Night Light not available for WLR Remote Models  
**CT** - Cold Temperature Operation (-20 deg. C)  
 (WL6 only)



3161 State Road  
 Bensalem, PA 19020  
 Tel: (800)872 0879  
 Fax: (215)244 4208  
 www.evenlite.com 10/07

<b>Fixture Schedule</b>	Project Name:	Approved By:
	Catalog No:	Type No: