



**SENTRY
CDI INDUSTRIAL SERIES
LED EXIT SIGNS**

**OPERATIONAL
MANUAL**

3161 State Road • Bensalem □ PA 19020 U□S□A
Telephone: (215) 244-4204 □ Fax: (215) 244-4208

SENTRY CDI SERIES LED EXIT

INSTALLATION AND OPERATING INSTRUCTIONS

IMPORTANT SAFEGUARDS

When using electrical equipment, basic safety precautions should always be followed including the following:

READ AND FOLLOW ALL SAFETY INSTRUCTIONS

1. Do not use outdoors.
2. Do not mount near gas or electric heaters.
3. Equipment should be mounted in locations and at heights where it will not readily be subject to tampering by unauthorized personnel.
4. The use of accessory equipment not recommended by the manufacturer may cause an unsafe condition.
5. Do not use this equipment for other than intended use.
6. Supply connections must be made inside the junction box and not inside the fitting.
7. Install using recommended junction box only.
8. Servicing of this equipment should be performed by qualified service personnel.

SAVE THESE INSTRUCTIONS

INSTALLATION PROCEDURE

Model CDI is designed to be mounted to a junction box (supplied by others). It can be either back, top or side mounted. The Single Face CDI back mounts to either a standard 2" wide "switch box", or a 4" square or octagon box. Top or side mount requires the optional canopy when using a 4" box.

BACK MOUNT INSTALLATION FOR SINGLE FACE CDI

1. Open enclosure by removing only the 2 tamperproof screws in upper corners of faceplate, detach hinged front cover, slide out PCB assembly and remove molded lightbox by unscrewing 2 captive mounting screws.
2. Punch out appropriate screw hole and center knockouts to fit junction box.
3. Connect supplied jumper wires to feed wires in junction box as per local code.
Black lead for 120V or Orange lead for 277V **CAP UNUSED LEAD**
White lead for Neutral
Green lead for Ground
4. Guide jumper wires through center hole and fasten enclosure to junction box.
5. Reinstall PCB assembly and molded lightbox into enclosure. Ensure that all cables are plugged into connector(s) on PCB.

- Route jumper wires straight up rear of enclosure, through notch in molded lightbox, and along top of enclosure. Push wires into appropriate "P" nut wire connectors, observing match of leadwire colors.
- Remove security shield and diffuser from front cover and knock out directional indicator(s) as required. Replace shield, diffuser and re-attach front cover.

SIDE OR TOP MOUNT INSTALLATION USING CANOPY

- Follow steps above, except knock out appropriate canopy mounting holes in top or side. On double face signs, remove rear shield and diffuser and knock out appropriate directional indicator(s).
- Fasten canopy to housing using 2 flanged nipples and 2 fixture nuts supplied, with flanges inside housing and fixture nuts inside canopy. Orient canopy with arrow facing hinged front cover.
- Fasten canopy mounting plate to junction box and secure to ceiling or wall with security screws (supplied by others).
- Fasten canopy to mounting plate with 4 tamperproof screws supplied.

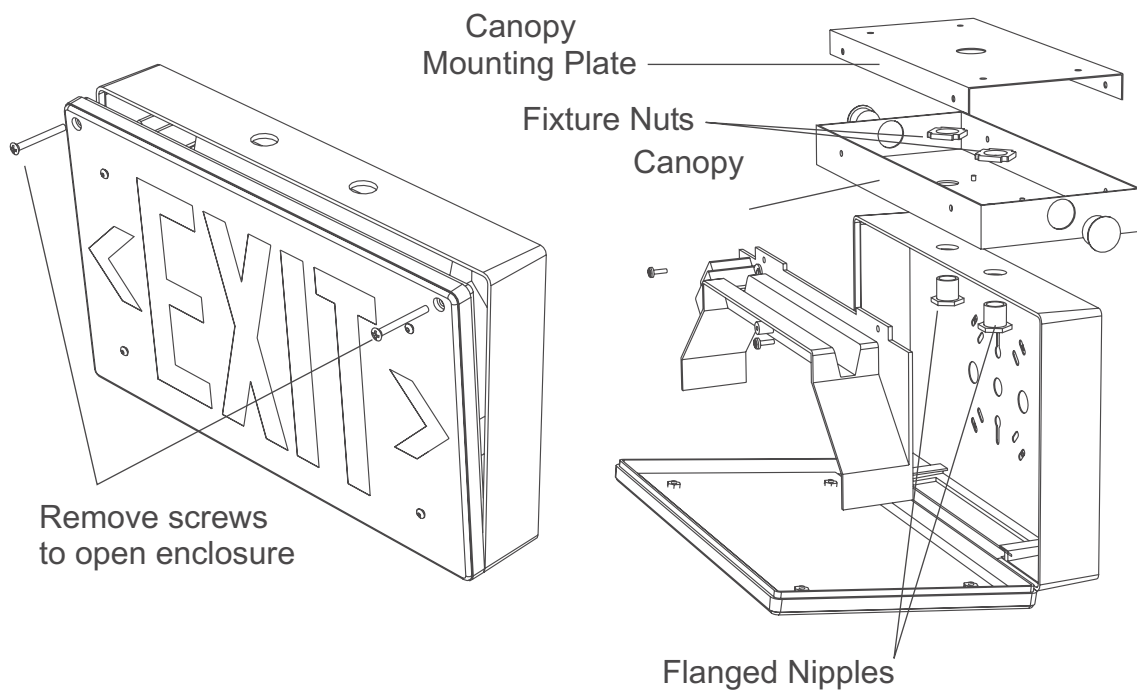

MASTER/REMOTE WIRING

Two connection terminal blocks, with connections marked Red and White, are mounted on the PCB assemblies in both the Master and Remote signs. Interconnect the Master and Remote with a 2 conductor cable (22 AWG minimum) per the National Electric Code, observing correct polarity. Distance of run should be 50 feet or less. Evenlite recommends a recognized cable suitable for alarm systems or thermostat controls.

COMPLETION OF INSTALLATION

- Close cover to fixture and reinstall 2 tamperproof screws.
- Reapply power and notify the authority having jurisdiction upon completion.

OPERATION

Energizing the AC supply will illuminate the unit.

DIAGNOSTICS

Self Powered (EM) versions are equipped with built-in battery diagnostics which indicates, via flashing of the indicator light, that the battery needs replacement. If flashing occurs after a new installation, check that the battery plug is properly inserted into the circuit board connector.

TEST - SELF POWERED VERSIONS

To test Self Powered (EM) versions, use test switch to simulate AC power outage. The indicator light will go out, and the sign will remain lit, indicating transfer to emergency mode; and remain lit on battery power until switch is released. Release of switch will automatically restore AC/battery charge mode, with indicator light on. Testing for longer periods is best accomplished by turning off AC circuit power to the unit. Signs should be tested in accordance with National Electric Code and NFPA 101 Life Safety Code requirements. Evenlite recommends monthly testing for 30 seconds and yearly testing for 90 minutes. Note that the batteries will take some time to reach full charge after a prolonged test, and that the unit cannot provide full duration operation should a real power outage occur before the batteries have had an opportunity to reach full charge. Evenlite recommends that long duration tests be limited to once yearly, and be timed when the area will be unoccupied afterwards.

TWO CIRCUIT INPUT OPTION (AC VERSIONS ONLY)

For AC versions with two circuit input, connect jumper wires from the main input to the top row of "P" nut wire connectors. Connect jumper wires from the backup input to the bottom row of "P" nut wire connectors. Note that both the main and backup voltages can be either 120V or 277V. They do not have to be the same voltage. Connect to the Black lead for 120V or Orange lead for 277V, and White lead for Neutral.

MAINTENANCE

This equipment is fully automatic and routine maintenance is limited to periodic testing. If trouble occurs, contact either the factory or local trained service personnel for further assistance.

BATTERY REPLACEMENT

To replace battery, disconnect branch circuit and open cover to fixture. Loosen molded lightbox by unscrewing 2 captive mounting screws. Pull top of lightbox out of fixture far enough to access battery in top channel. Unplug battery connector from Printed Circuit and slide battery out of channel. Replace battery, reconnect to Printed Circuit and fasten lightbox to enclosure. Close fixture cover and reconnect branch circuit. Replace battery only with Evenlite part B310011.

This product contains Ni-Cd batteries. Used Ni-Cd batteries may not be disposed of in the municipal solid waste stream. Ni-Cd batteries must be recycled or disposed of properly. For information on local recycling drop off points, phone toll free 1-800-BATTERY.