

Contractors Guide
Emergency Lighting Central Inverter System
Step By Step Procedures
33,000 Watt/VA (Three Phase)
Installation Guidelines

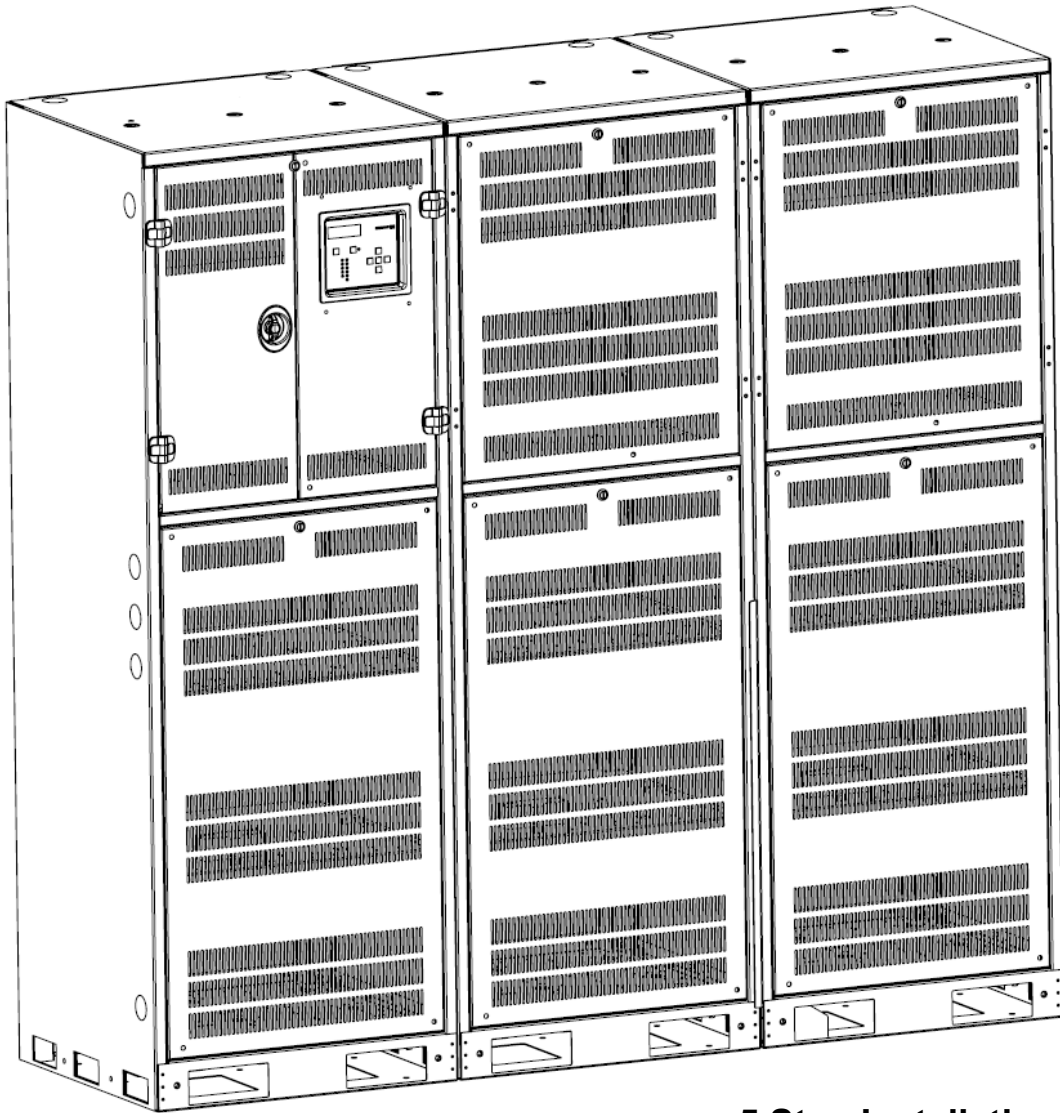

5 Step Installation:

1. Mounting the Cabinet
2. Install / Connect Batteries
3. Install Conduit
4. Install AC Wiring
5. Energize System

For additional information, please refer to the Installation/Operation Manual

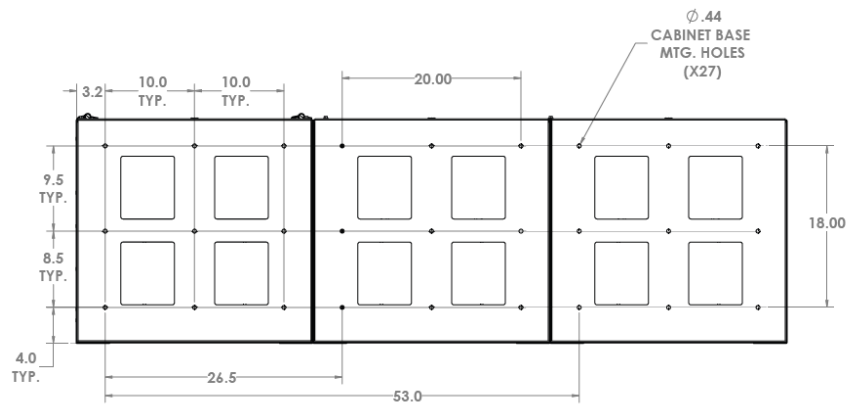
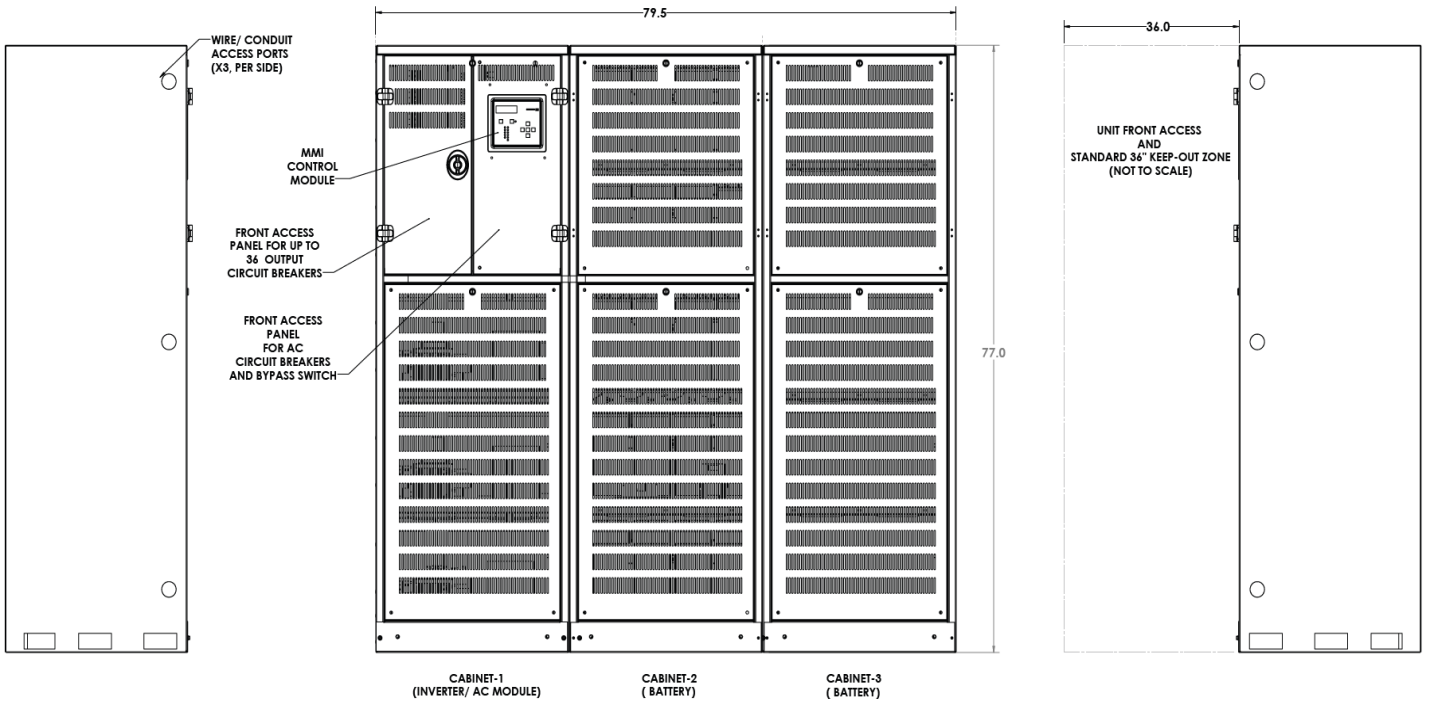
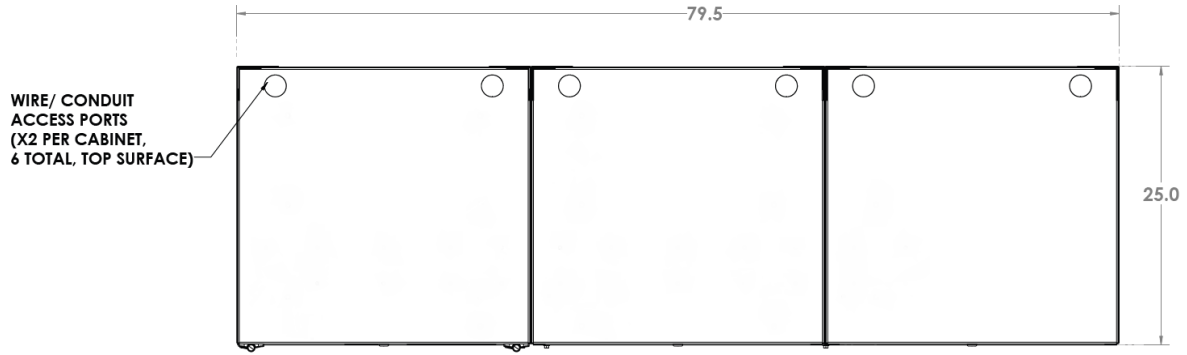

Overall Mounting and Product Outline Dimensions

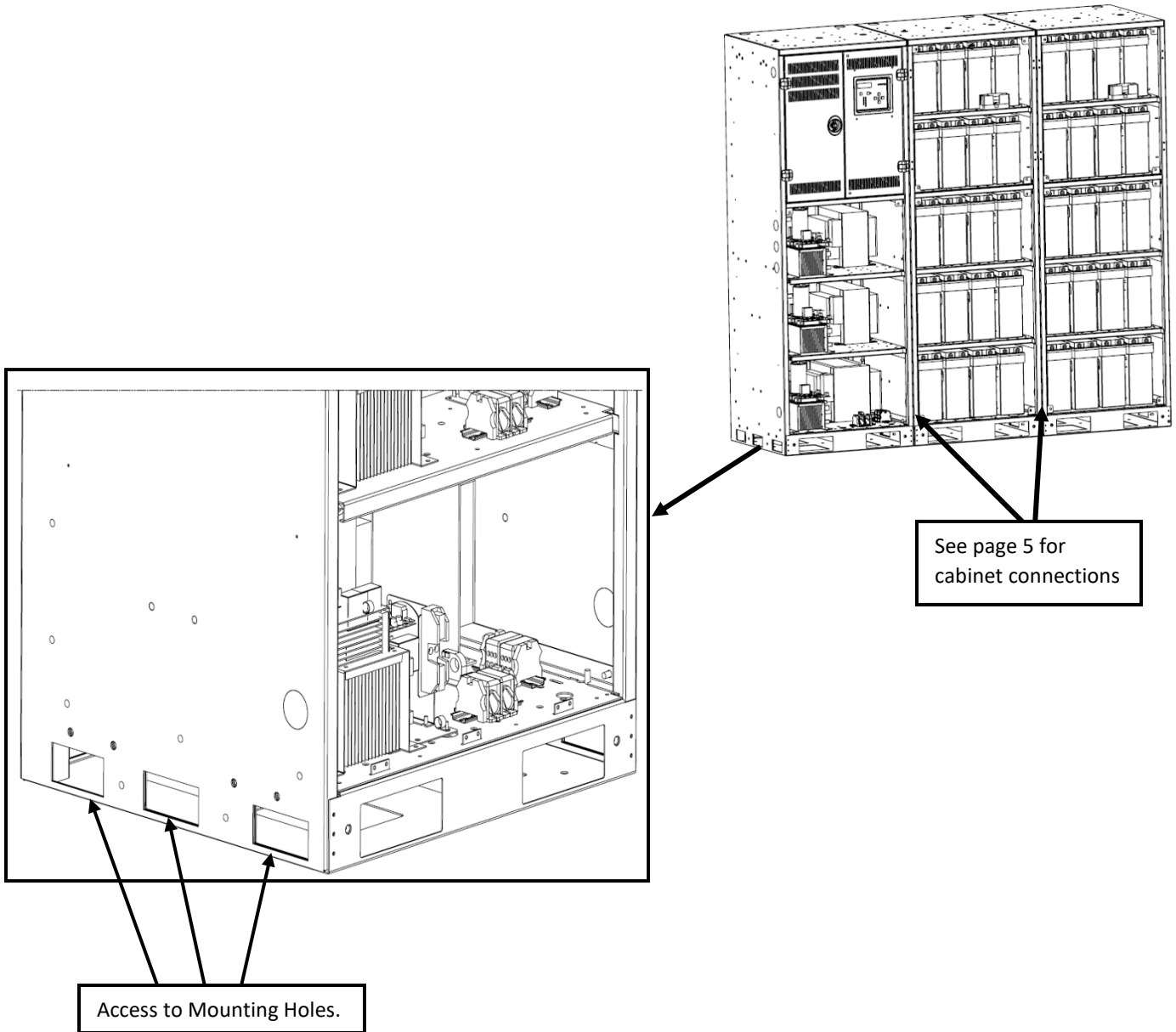

Prepare floor so that it is level and smooth. Secure Inverter Cabinet into floor first, We recommend concrete wedge anchors such as the Hilti brand Wedge Anchor series Kwik Bolt TZ or equivalent. (Hardware provided by others).

Note - Uneven surfaces may cause difficult front cover removal/installation

Step 1.

Mounting the Inverter Cabinet

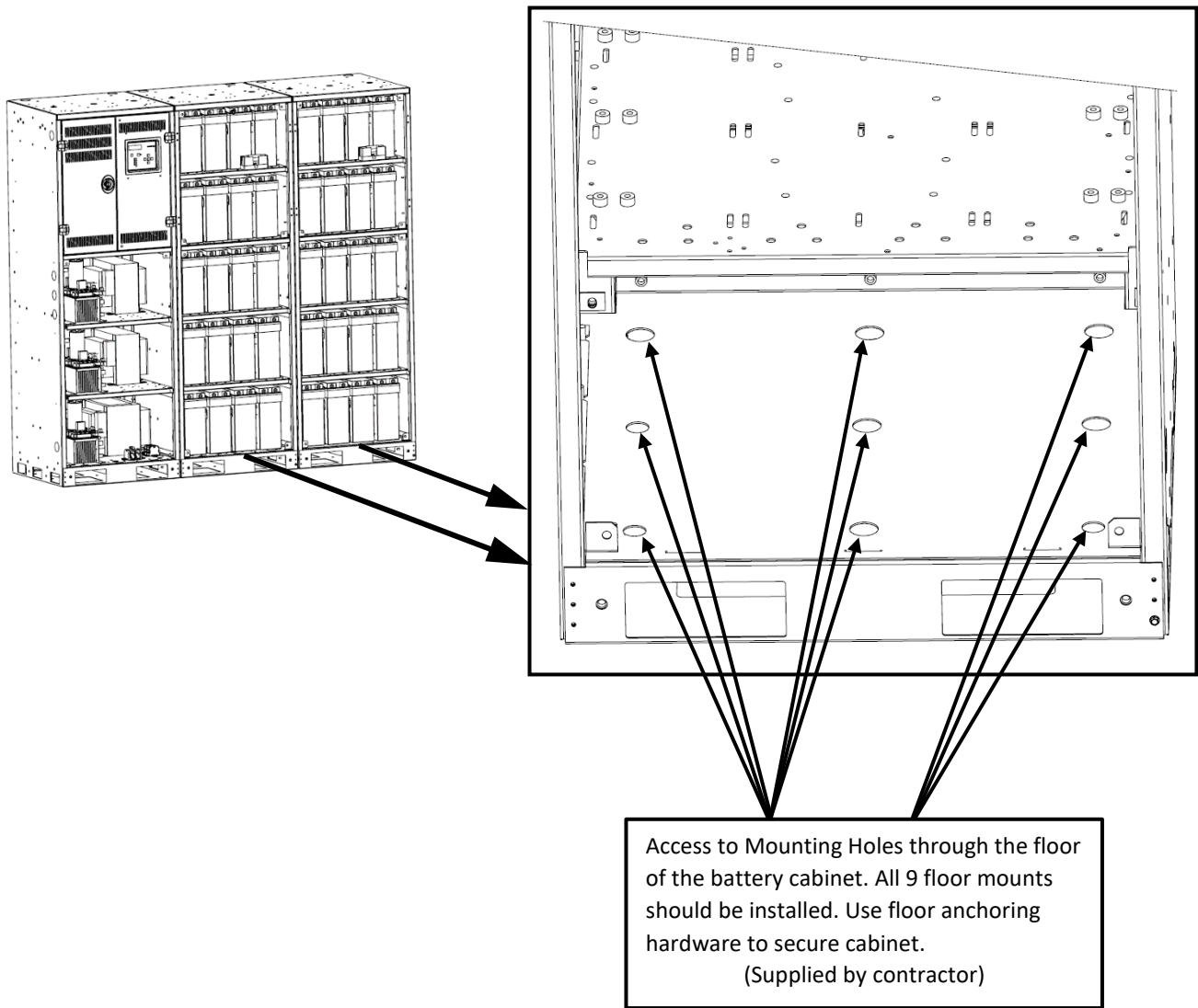

Prepare floor so that it is level and smooth. Secure battery Cabinet(s) into floor using Concrete Wedge Anchors such as the Hilti brand Wedge Anchor series Kwik Bolt TZ or equivalent. (Hardware provided by others).

Note - Uneven surfaces may cause difficult front cover removal/installation

Step 1 - Continued

Mounting the Battery Cabinet

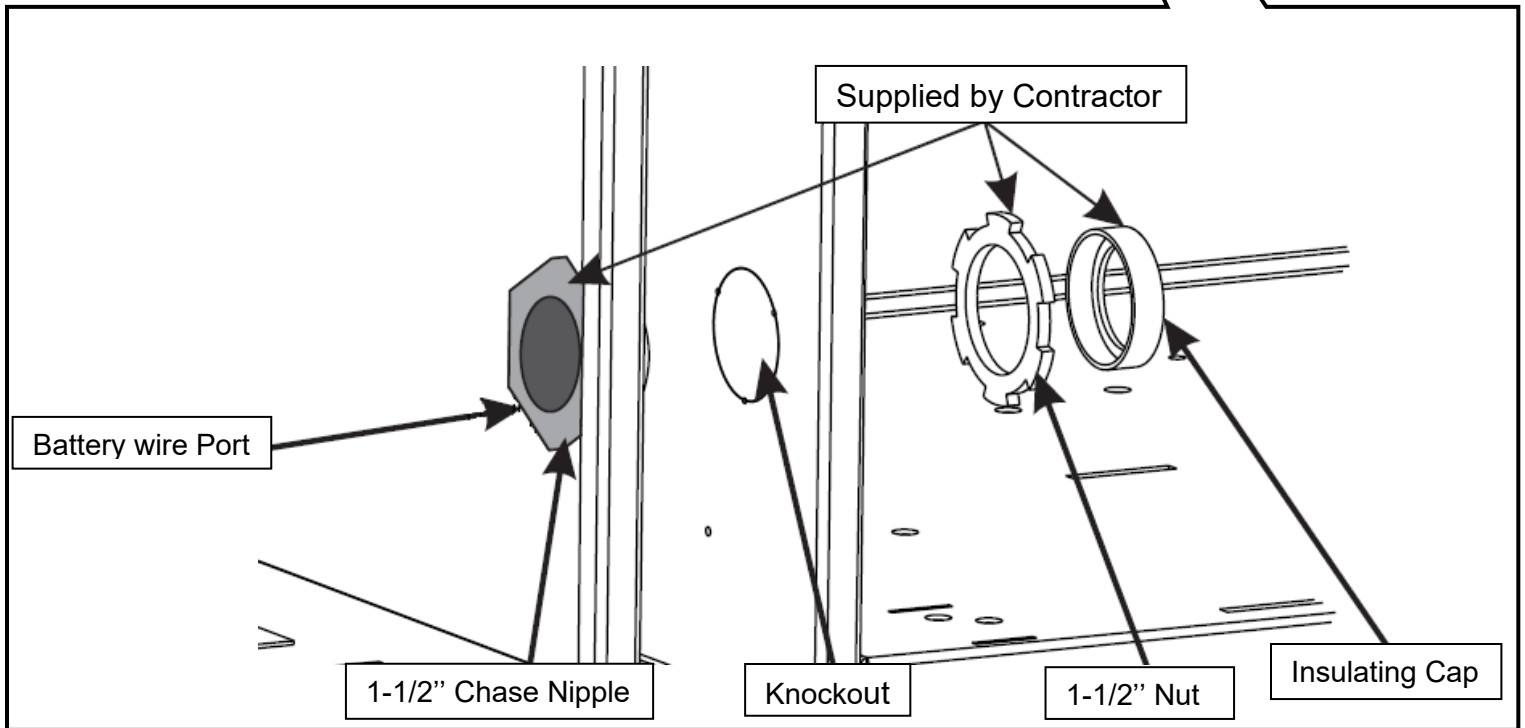
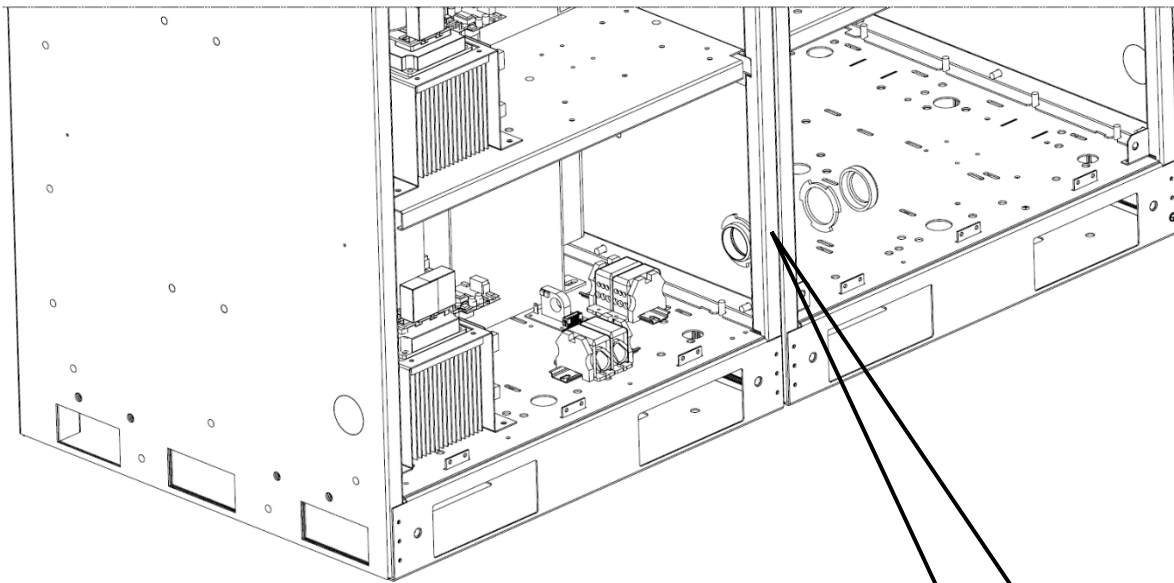

Step 1 - Continued

Connecting the Cabinets

Check List

Ensure that all the factory provided items are present and ready:

Batteries – Inspect each battery to ensure no shipping damages have occurred.

Battery Interconnect wires (pre-lugged) and String connection wires (black for negative, red for positive)

Battery Fuse

Busbars with hardware (bolt, flat washer, lock washer)

Temperature Sensor busbar

Tools required – Insulated torque wrench w/10mm socket, 3 mm Allen & 6 mm Allen for power distribution blocks

Battery Loading and Connection Procedure

Important Note: This procedure provides step-by-step instructions for safely connecting batteries. It is crucial to follow these instructions carefully to ensure safety and correct installation.

Caution: Each battery can weigh up to 121 lbs. (55 kg). Exercise caution when lifting and handling batteries. Short-circuit current ratings of these batteries can reach several thousand amps. Always use extreme electrical safeguards to ensure proper handling and installation. Ensure proper PPE is worn when installing.

Note: These batteries are of the front access type. Each 12V battery has a positive terminal on the right and a negative terminal on the left. Each Busbar connects the positive terminal of one battery to the negative terminal of the other battery directly next to each other to form a series connection.
Ensure that all bolts are torqued to the correct setting. Do not over-torque the bolts, as it may lead to damage or complications.

Pro-Tip - It is essential to secure the connections as you progress with the installation and not leave it until the end. This technique reduces the risk of forgetting or missing a bolt. As the number of connected batteries increases, the string voltage rises. Therefore, securing connections promptly is safer.

Step 2.

Installing and Wiring the Batteries

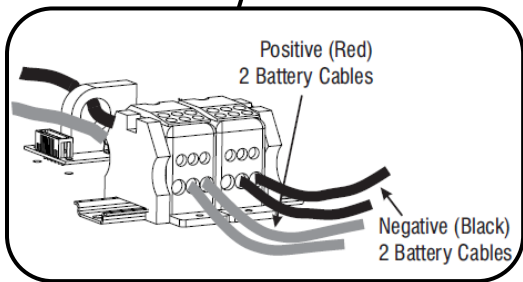
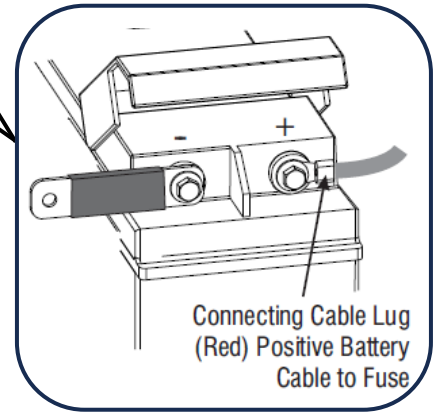
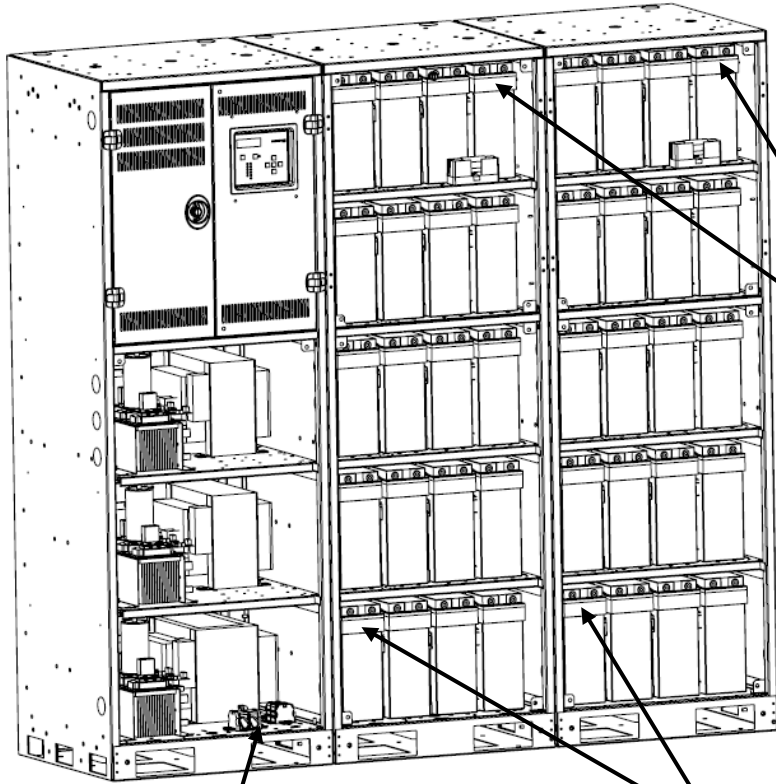

Inverter Battery Cable Connection Terminal Block
2 Battery Strings (parallel connection)

Nominal DC Voltage
192VDC (32 Batteries)
240VDC (40 Batteries)
See Detailed Diagram on Cabinet Door

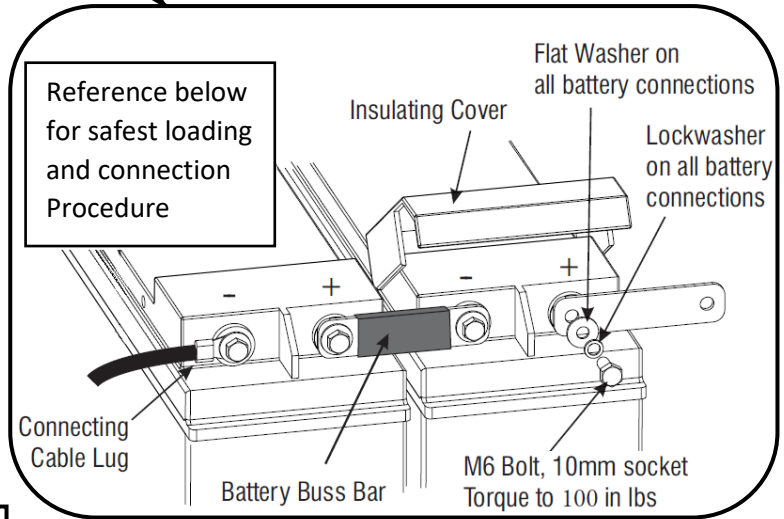

Step 2. - Continued

Installing and Wiring the Batteries

2.0. Loading and Preparing Batteries for Connections

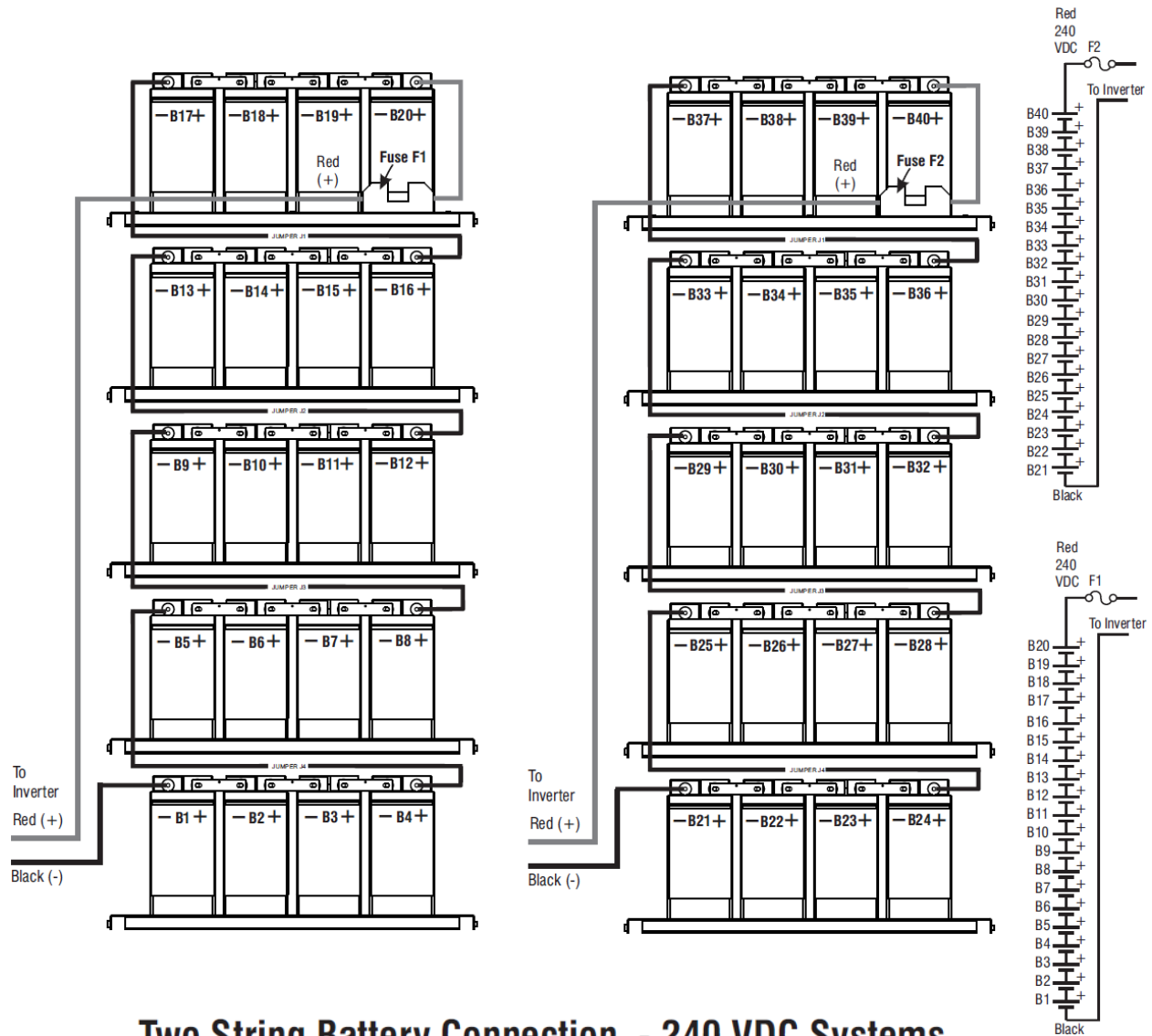

Two String Battery Connection - 240 VDC Systems
 Battery Part Number B250024
 12.0VDC 160ah Front Access VRLA Maintenance Free Lead Calcium Battery

Step 2. - Continued

Installing and Wiring the Batteries

2.1. Loading the Batteries - Load all the batteries into the cabinet such that 4 batteries are on each shelf.

2.2. Spacing the Batteries - Space the batteries equally and centered in the middle. Ensure proper alignment (front to back and side to side) for the bus bars to fit between the batteries on the battery terminals. Note - It is best to pre-fit the busbar between the batteries without installing the hardware to gauge the proper distance required between the batteries. Reposition batteries as necessary to ensure perfect alignment.

2.3. Measuring the Batteries - Measure the DC voltage of all the batteries. Each battery should measure at least 12.6-12.9 VDC. Please contact the factory immediately if any batteries measure below 12.6VDC.

Pro-Tip: It is beneficial to pre-make all bolt assemblies (flat-washer/lock-washer/bolt) and place two of these directly in front of each battery along with the busbar for easy access. Properly spacing the batteries for busbar fit and bolt preparation will be of great safety and time benefit!

Wiring the Batteries

Note - Please see wiring diagram mounted on the battery cabinet door and in the Contractors Guide.

2.4 String Positive and Negative Connection - Connect the factory-provided Red String connection wire (string positive) between the Inverter cabinet positive terminal and the battery cabinet fuse block. Connect the jumper wire from the fuse block to the positive terminal of the top right battery. Connect the Black String connection wire (string negative) between the Inverter cabinet's negative power distribution block to the negative terminal of the bottom left battery (string negative point).

2.5. Battery-to-Battery Wire Connections - Connect the battery-to-battery Interconnect wires between shelves. Start with the positive terminal of the right battery on the bottom shelf and connect it to the negative terminal of the left battery on the shelf directly above. Repeat this process for all provided battery-to-battery Interconnect wires.

Step 2. - Continued

Installing and Wiring the Batteries

Installation of interconnection busbars

2.6. Outside Battery Busbar Connections – At this time, only install two busbars per shelf which connects the outside left two batteries and the outside right two batteries. Note – Leaving the middle connection open at this time will keep the DC voltage to a maximum of 48VDC at any point in the cabinet. Repeat this operation for all the batteries on all battery shelves.

Caution – each time a busbar is connected in the next final steps, the battery string voltages get higher. Please exercise extreme caution and safety since the final string voltages are lethal.

2.7. Temperature Sensor - Connect the middle Temperature Sensor busbar to the top battery shelf.

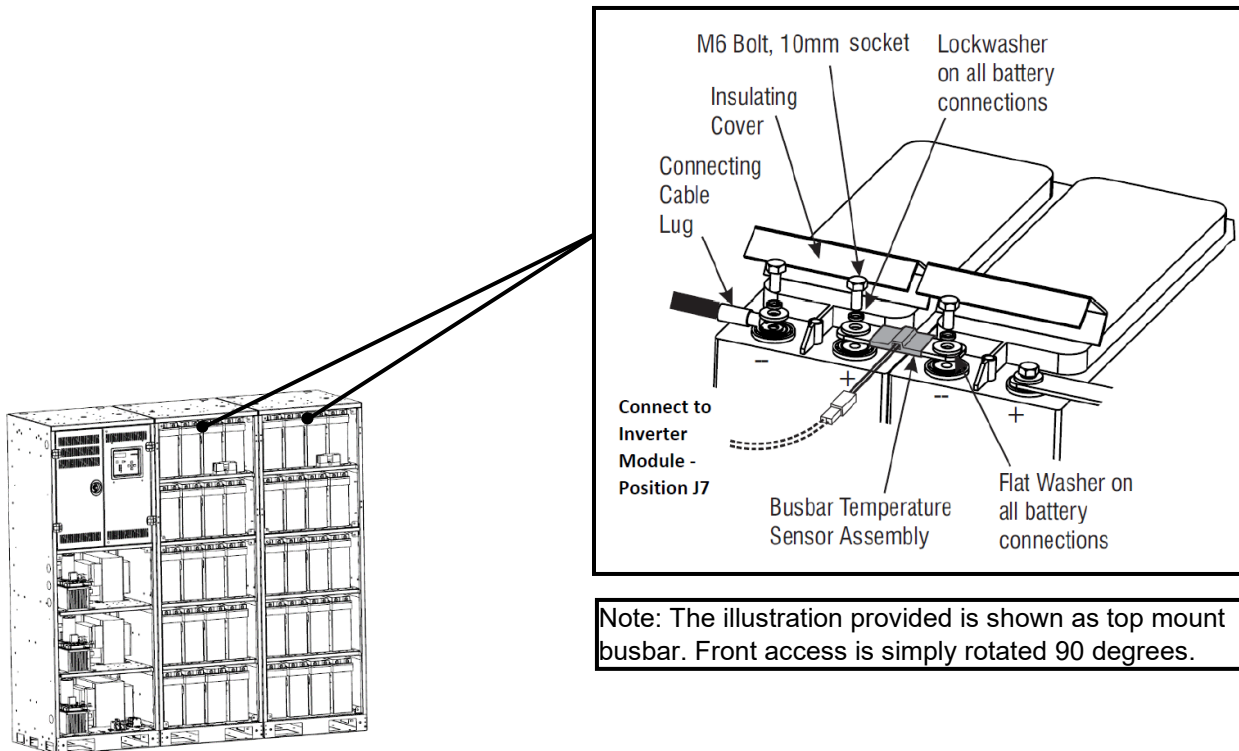

Step 2. - Continued

Installing and Wiring the Batteries

2.8. Bottom Busbar - Connect the middle busbar to the bottom shelf.

2.9. Remaining Busbars - Connect the middle bus bar above the bottom shelf, and then connect the middle busbar to the shelf below the top battery shelf.

2.0.0 Final Busbar - If the system has 16 batteries, the connections are complete. If the system has 20 batteries, make the final connection by connecting the middle busbar to the middle shelf. At this point, all busbars should be installed including the Temperature Sensor busbar.

Finalizing the Installation

2.1.1 Measuring DC Voltages - Measure the string voltage and ensure it meets the system requirements. String negative is on the far-left battery on the bottom shelf, string positive is on the far-right battery on the top shelf.

NOTE: For 20 batteries, the string voltage should measure at least 240 volts DC. For 16 batteries, the string voltage should measure at least 192 volts DC.

2.1.2 Temperature Sensor connection - Install the Temperature sense cable between the Temperature Sensor busbar and the inverter module. Note – the factory has pre-installed the sense wire into the inverter module, simply route the cable to the Temperature Sensor busbar.

2.1.3 Multi Battery Cabinet Configuration - If multiple cabinets and Battery Strings are used, repeat this process. Once finalized, install the 100Amp DC Fuse into its fuse block located on the top shelf.

Step 2. - Continued

Installing and Wiring the Batteries

Step 3.

Installing the AC Conduit

See Illustrations on page 2

Use Provided Knock-Outs located on Top of Inverter Cabinet.

Note – Drilling into cabinets may VOID warranty - metal shavings can short circuit electronic components.

Knock-Outs are 1-1/2"

Input and Output Wires should be run in separate conduit per NEC.

Follow all Local and National Electrical Codes (NEC)

Step 4.

Installing the AC Wiring

See illustration on page 16

Ensure the AC Input Breaker CB1 is in the OFF (Down) position before starting. Refer to units rating plate for AC Input and Output AC ratings.

Wire AC input directly breaker, if equipped with a maintenance switch wire directly to terminal blocks on din rail. Wire Input Neutral and Ground connections to appropriate Neutral and Ground Bars.

Do not share Neutrals with Emergency and Non- Emergency loads.

Connect AC output wires to the Normally-On terminal block on the left side of the cabinet or to output circuit breakers starting from the bottom if provided.

AC Output Breakers are Optional. Follow all Local and National Electrical Codes (NEC).

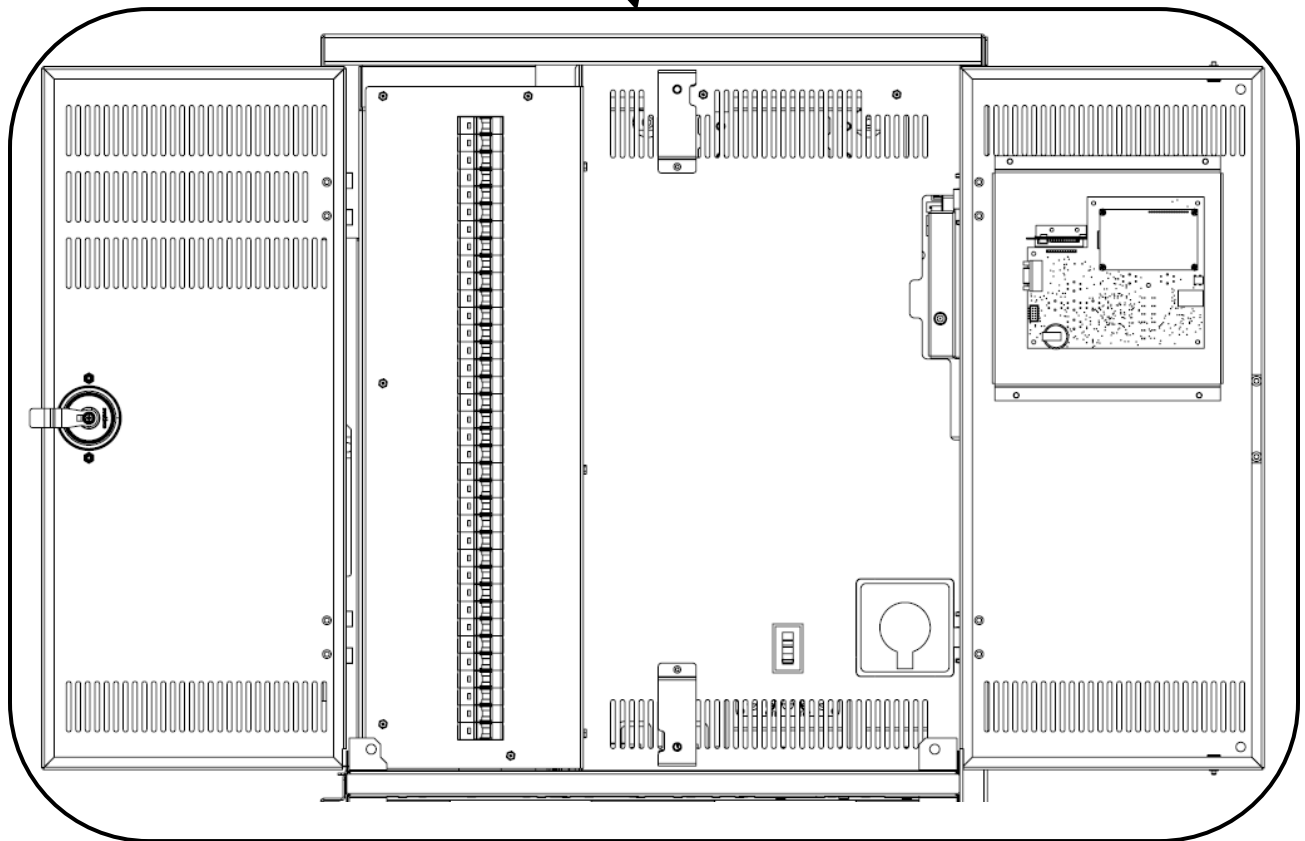
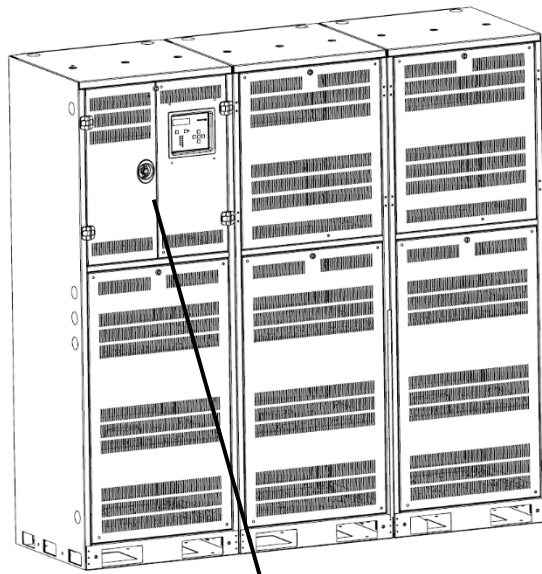

Step 1. Begin with unlocking and opening both doors on inverter cabinet

Panel removal

Step by step guide to remove A/C module panels

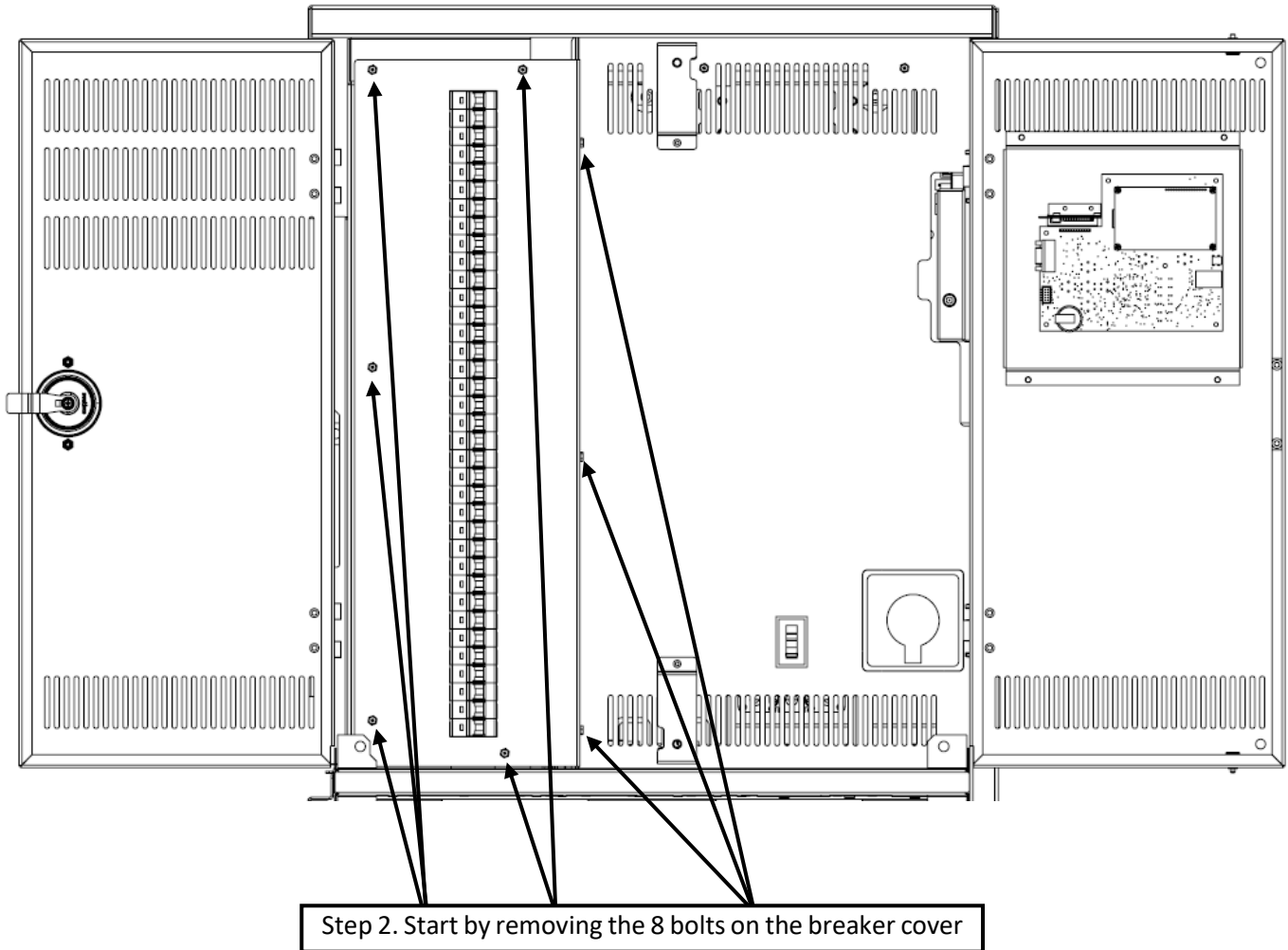

Panel removal - Continued

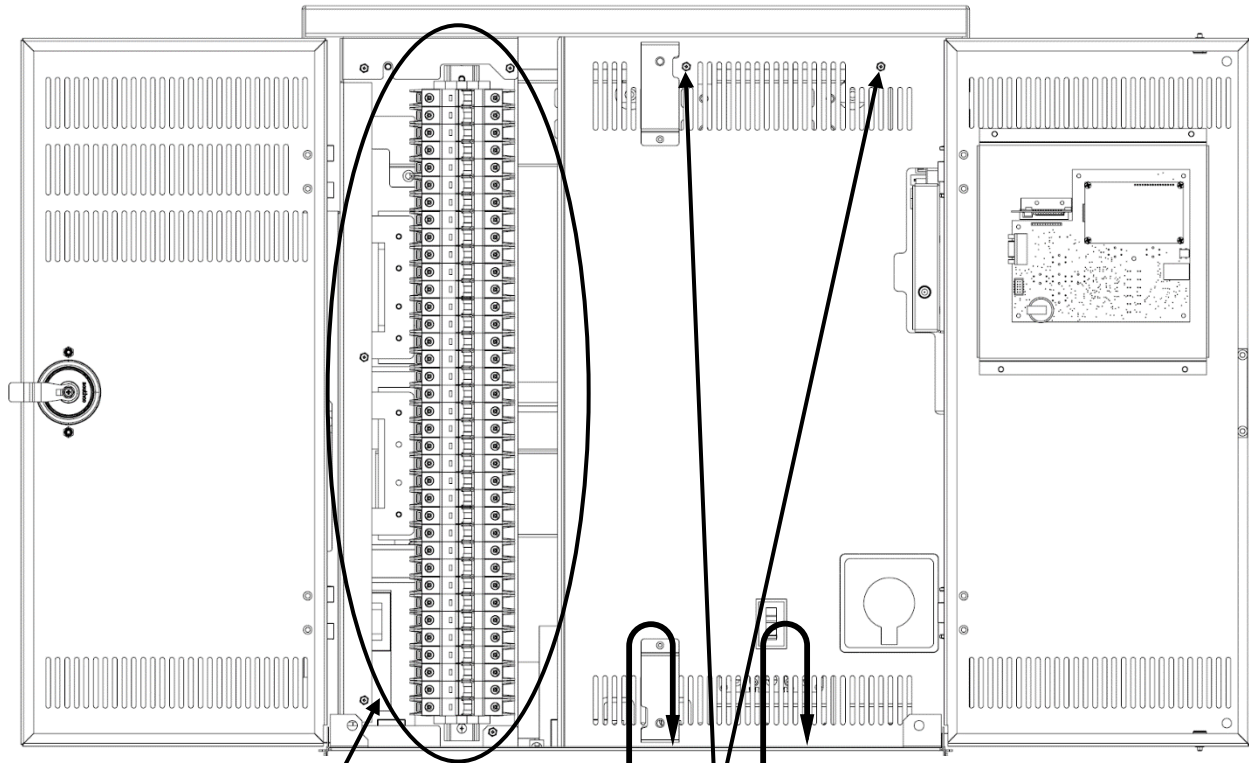

Step 3. Remove breaker cover

Step 4. Remove the 5 bolts and 3 nuts and remove A/C section cover

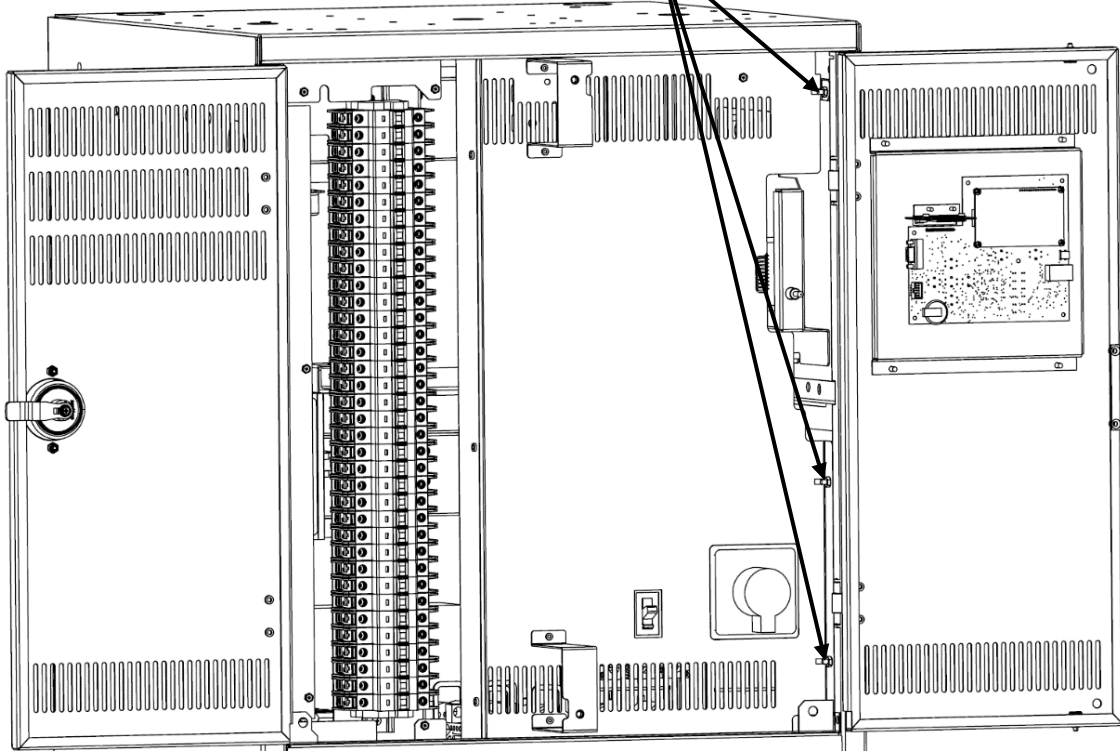

Panel removal – Continued

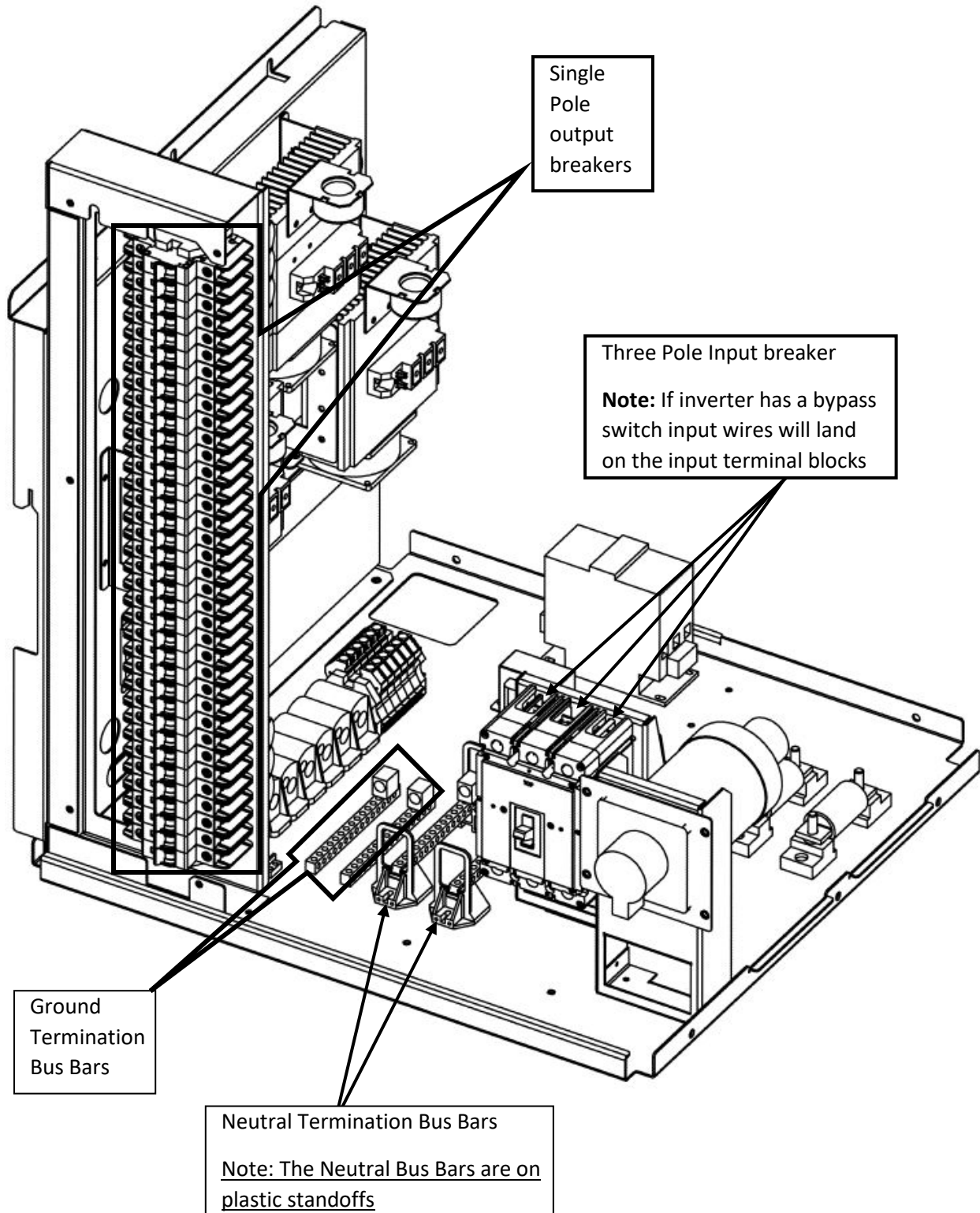

Step 4 - Installing A/C Wiring

Step 5

Starting Up/Energizing the Unit

Ensure batteries are installed and the wiring is checked per Step 2.

Ensure AC Power is present and lighting loads are connected per Step 4.

Flip on Input Circuit Breaker CB1.

Flip on System's On/Off Switch located behind the right of the Interface Panel. The System will go through start up diagnostics and go into charge mode if there are no errors. Press the system test button or momentarily drop AC power to energize emergency power and ensure that the inverter can support the lighting loads without going into a fault condition.

Replace and secure all AC Breaker Panels in the reverse order under panel removal steps. Then close the front covers to Cabinets.

Contents of Shipment 33KW Models include:

Batteries – 40 pcs for 33KW

Battery Cable Kit – All Models

Installation/Operation Manual – All Models

Tools Required for Installation

(Typical all models)

3/8" Nut Driver and/or 3/8" Socket and Ratchet

Straight Blade Screwdriver(s)

Square Head (Robertson) Screwdriver

Phillips Head Screwdriver

10MM Socket and Ratchet – or – 10MM Wrench (Torque set to 100 in-lbs.)

3 mm & 6 mm Allen Head (Only for Side-by-Side mounting – Battery Cable Installation)

Hardware for securing cabinet to floor – i.e. Hilti Kwik Bolt TZ or equivalent

Multi-Meter capable of DC and AC Measurements