



EVENLITE

Lives Depend On Us

CURVE

ARCHITECTURAL INDOOR LED EMERGENCY LIGHT

INSTALLATION AND OPERATING INSTRUCTIONS

IMPORTANT SAFEGUARDS

Equipment is intended for connection to **FLEXIBLE CONDUIT ONLY**

When using electrical equipment, basic safety precautions should always be followed including the following:

Use Flexible Conduit Only

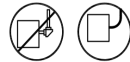

READ AND FOLLOW ALL SAFETY INSTRUCTIONS

1. Install in accordance with all national and local electrical codes.
2. Disconnect power at circuit breaker or fuse before installing or servicing the unit.
3. DO NOT mount in hazardous locations, near gas or near electric heaters.
4. DO NOT let power cords contact hot surfaces.
5. Equipment should be mounted in locations and at heights where it will not be readily subject to tampering by unauthorized personnel.
6. DO NOT use accessory equipment not recommended by the manufacturer. The use of such equipment may cause unsafe conditions and will void the unit's warranty.
7. DO NOT use this equipment for other than its intended purpose.
8. All servicing should be performed by qualified personnel only.
9. Allow battery to charge for 24 hours before first use.
10. For indoor use only.

SAVE THESE INSTRUCTIONS

2575 Metropolitan Drive • Trevose, PA • 19053 U.S.A

Telephone: (215) 244-4204 • Fax: (215) 244-4208

BASIC FUNCTIONALITY & FEATURES

Open enclosure by pressing the snap tabs marked "Press" (RELEASE TABS).

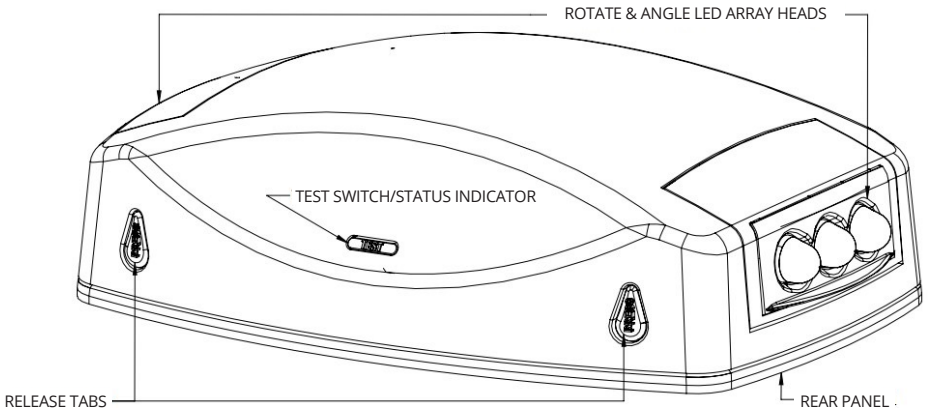
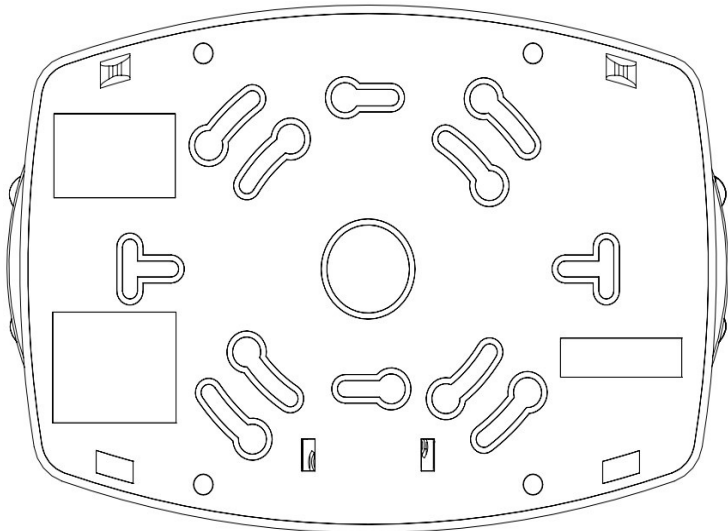

FIGURE A

Prior to removing knockouts, support rear panel on a base to prevent panel deflection and/or damage to the cover's flatness.



REAR VIEW

FIGURE B

INSTALLATION INSTRUCTIONS

1. Remove the cover by pressing the "RELEASE TABS" marked "Press" [FIGURE A]
2. Remove the appropriate knockouts on the mounting plate for the selected Back Mount or Conduit Entry. See FIGURE C, D, E & F.
3. Connect the fixture wires to the power supply wires using the provided wire nuts. The wiring is as follows:

9W Unit

Orange Wire – 277 VAC Input

Black Wire – 120 VAC Input

White Wire – Neutral

16W Unit

Black Wire – 120-277VAC Universal Input White

Wire – Neutral

Blue Wire – Remote Lamp Negative (-)

Yellow Wire – Remote Lamp Positive (+) (9.6VDC)

4. Attach the mounting plate to the mounting surface or junction box via the previously established holes.
5. Check the mounting plate for level before moving on.
6. Snap the front housing onto the back housing by laying the housing on the top snaps, then rotating into the bottom snaps. [FIGURE B]
 - a. When snapping the unit together, ensure that the plug and mating connector are aligned so that the unit receives power.
7. Adjust the lamp heads down and outward for the designed emergency illumination.

WIRING INSTRUCTIONS

Back Mount Wiring Instructions (9W Wiring)

FIGURE C

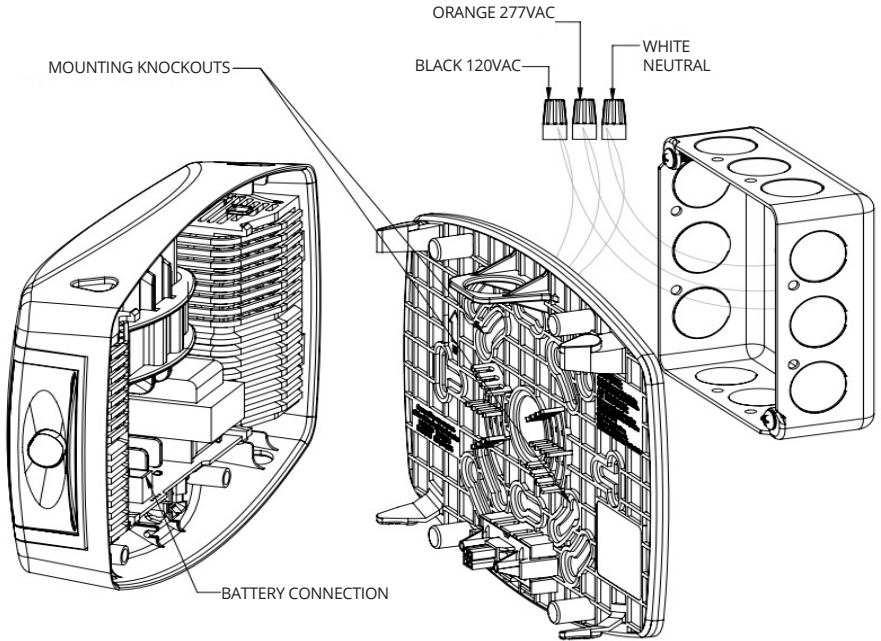

Back Mount Wiring Instructions (16W Wiring)

FIGURE D

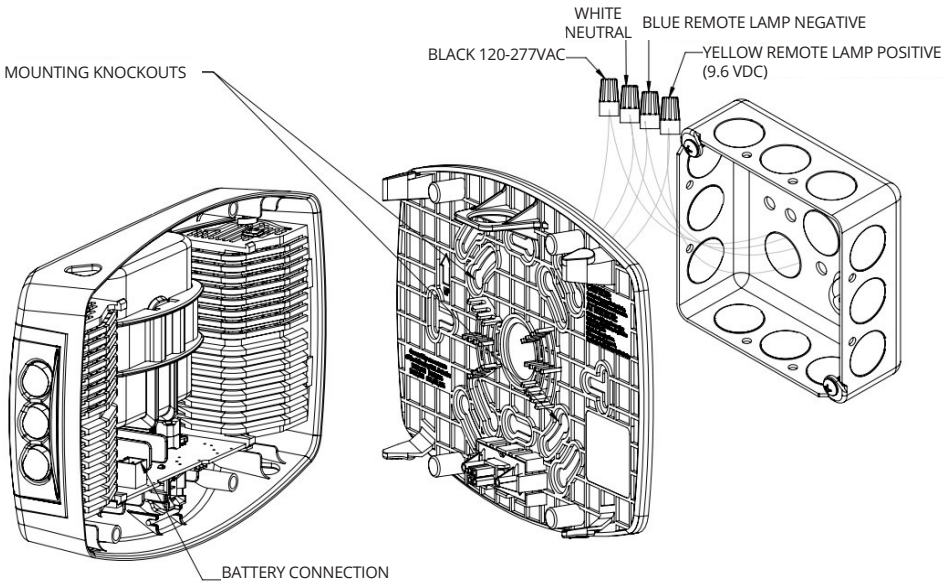

WIRING INSTRUCTIONS (CONT.)

REMOTE LAMP HEAD WIRING (16W UNIT ONLY)

NOTE: When remote lamps heads are used, the main housing will reduce light output to 10W to provide power to the remote lamp heads.

NOTE: Only use approved multi-voltage lamp heads with the unit.

Prior to mounting the unit to the junction box as listed in step 4 above [INSTALLATION INSTRUCTIONS], attach the remote lamp wires to the blue and yellow wires via wire nuts.

When installing remote lamps, ensure that adequate space is provided between the line voltage wires and the remote lamp wires [FIGURE D]. Always wire the devices in accordance with local and national electrical codes.

Conduit Entry Surface Mounting (9W UNIT ONLY)

NOTE: To avoid interference with components in the housing, use the most compact wire connectors appropriate to the wire gauge.

1. Remove required keyhole slots from mounting plate to support the product on the given wall type.
2. Make code-approved wire connections to the branch circuit and remote lamps (16W Unit only).

FIGURE E

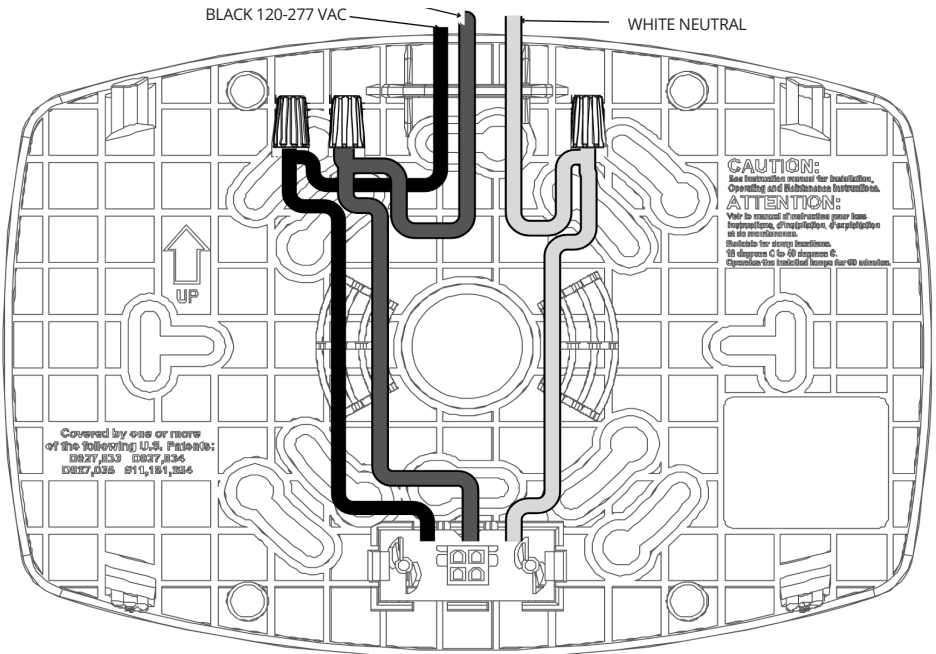

NOTE:
Secure wire connectors near the upper latches. AVOID grouping wires and wire nuts in the area of this PCB and the battery as this may limit engagement of connector to PCB.

INSTALLATION INSTRUCTIONS (CONT.)

Conduit Entry Surface Mounting (16W UNIT ONLY)

FIGURE F

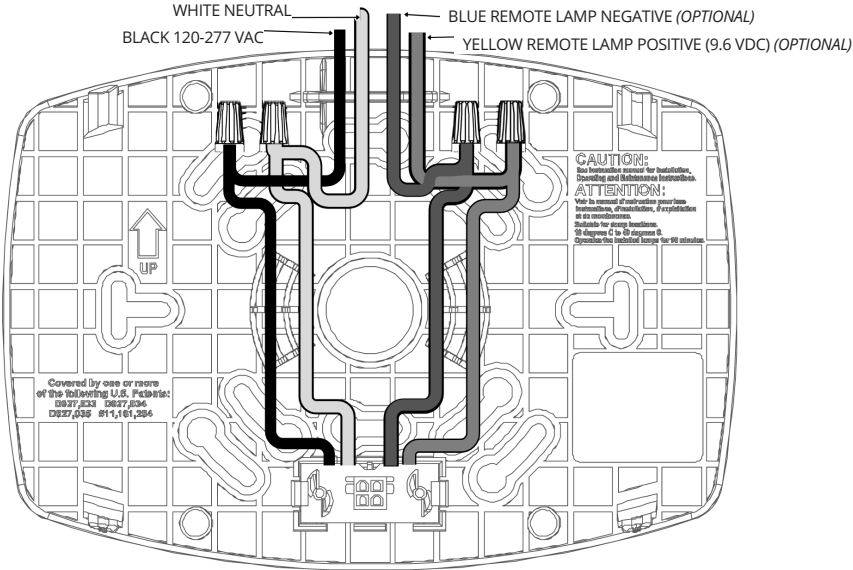

MOUNTING INSTRUCTIONS

WALL MOUNT BACK POWER FEED

1. Open enclosure by pressing the snap tabs marked "Press" (RELEASE TABS).
2. Remove appropriate knockout in back plate and mount back plate to J-box
3. Knockout in center of back plate and feed wires through the hole.
4. Securely backplate to J-box.
5. Connect the fixture wires to the power supply wires using the wire nuts provided. Connect the white wire to neutral, connect the black wire to the hot lead. Cap the unused lead. Press the wires into the J-box (Refer to Wiring diagram below).
6. Connect remote wires if this item with remote capability. Refer to below instructions for remote wires.
7. Plug battery male connector into battery female connector on PCBA.
8. Snap the front cover on the back plate.
9. Restore power and press test button. LED heads will turn on.
10. Adjust the lamp heads direction as needed.

WALL MOUNT CONDUIT ENTRY (TOP POWER FEED)

1. Open front cover and remove top knockout on top flange of fixture.
2. Secure conduit (or surface raceway) to knockout and feed wires.
3. Remove appropriate knockout on back plate and mount to wall.
4. Refer to above 5-10 steps in Wall Mount-Back Power Feed.

CONNECTING REMOTE POWER HEAD (OPTION 16W)

Connect extended remote wires to remote wires using wire nuts. Yellow is positive (+), blue is negative(-). Support up to 6 watt of Telesis PRW LED 16-Watt Capacity with 2 x 5-watt lamps and up to 6-watt remote capacity.

MAXIMUM MOUNTING HEIGHT (9W UNIT) = 21 FEET

MAXIMUM MOUNTING HEIGHT (16W WITH REMOTE CAPACITY) = 21 FEET

MAXIMUM MOUNTING HEIGHT (16W UNIT) = 28 FEET

OPERATIONS

All units are furnished with self-diagnostics, which will automatically perform a functional test every 28 days. If a manual test is required, the method is as follows:

For a 30 second Functional Test

1. Press and hold the test button for 1 second.
2. The unit will run a 30 second test.
 - a. While in test mode the LED indicator will flash green.

For a 90-minute Duration Test

1. Press and hold the test button for 4 seconds.
2. The unit will run a 90-minute duration test.
 - a. While in test mode the LED indicator will flash green.
 - b. If the battery charge is insufficient, the 30 second functional test will be performed instead.

NOTE: The lamp current will be calculated upon the running of the first self-diagnostic test. Subsequent self-diagnostics checks will verify the lamp current against the initial measurement.

LAMP ADJUSTMENT

FIGURE G

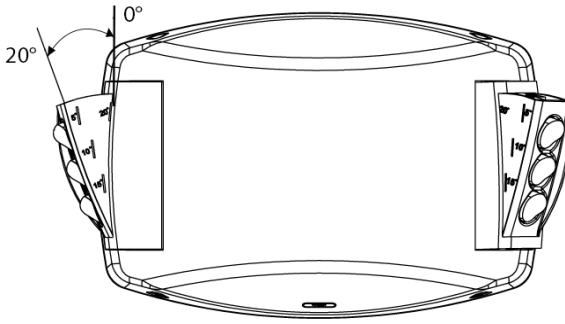

This Emergency Light has Two Adjustable LED lampheads. Each lamphead can be tilted down up to 20° and rotated up to 90° away from the wall. See "SPACING CHART" for recommended Tilt Adjustment located on https://www.evenlite.com/Downloads/specification-sheets/Curve.pdf?doing_wp_cron=1708531358.3583879470825195312500



SCAN TO SEE
SPACING
CHART

FIGURE H

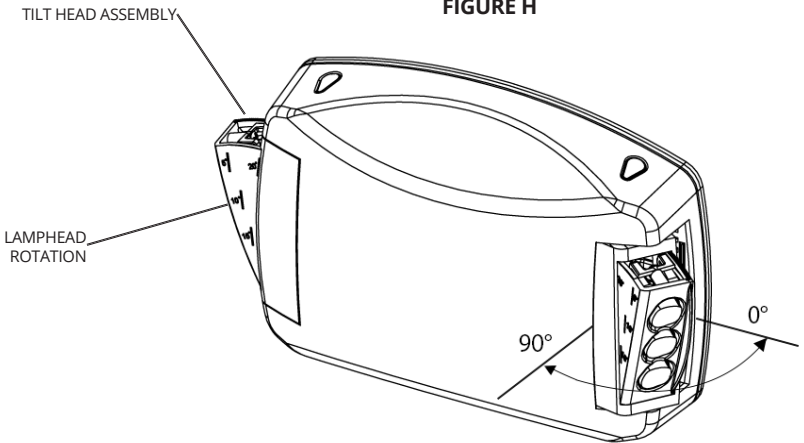

SELF-TESTING / SELF-DIAGNOSTICS

This unit meets the requirements of NFPA 101 for Periodic Testing of Emergency Lighting Equipment. It provides visual indication of unit malfunctions including:

Battery Fault
Charger Fault
Transfer System Fault
Lamp Fault

SELF-TEST

An automatic self-test and diagnostic function will be performed every 28 days. A load test will be performed for 30 seconds checking for a lamp, battery or transfer system fault.

This automatic self-test and diagnostic function will be performed only if the battery is fully charged. If not, the test will automatically reschedule. The charger function is monitored continuously.

DEFEAT MONTHLY DIAGNOSTICS TESTING

The option to defeat the standard monthly testing is available as a factory option. This will allow the user to bypass the testing schedule that is provided standard with all units. .

USER-TEST

A manual USER-TEST can be performed for 30 seconds or 90 minutes. By pushing the "TEST" Switch for 1 second, the lamps will illuminate for 30 seconds. If the "STATUS" indicator shows GREEN indicating a fully charged Battery and the Switch is pushed for 4 seconds, the lamps will illuminate for 90 minutes. If the Battery is not fully charged, the 30 second test will run. In either mode, the USER-TEST can be canceled by pushing and holding the "TEST" Switch for 1 second after the lamps turn on.

LAMP LOAD LEARN

The self-diagnostic system "learns" the lamp load during the first test. Subsequent tests compare the measured lamp load during the test to the learned lamp load values.









CLEARING FAILURE INDICATIONS

Failure indications can be cleared by correcting the indicated fault and pushing and holding the "TEST" Switch for 1 second.

STATUS INDICATIONS

Status indications for the self-testing / self-diagnostic system are shown on the following page.

STATUS INDICATIONS

 Hi Charge	 Full Charge
 Insufficient Charge	 Testing
 ¹ Transfer Failure	 ³ Charger Failure
 ² Battery Failure	 ⁵ Lamp Failure

STATUS DISPLAY	FUNCTION	ACTION
Continuous Green	Battery Float Charging	None
Continuous Red	Battery Bulk Charging	Wait for Charge Completion
Flashing Green	In Test Mode	Wait for Test Completion
Alternate Red and Green	Insufficient Charge For User Test	Wait for Adequate Charge*
Red One Blink (ON/Pause)	Transfer System Failure	Factory Service Required
Red Two Blinks (On/Pause)	Battery Failure	Verify Battery Connections/ Replace Battery
Red Three Blinks (On/Pause)	Charger Failure	Factory Service
Red Five Blinks (On/Pause)	Lamp Failure	Replace Lamps, Factory Service

**For 90-minute User Tests, wait for full charge.
For 30 second User Test, try again after an hour of charging.*

TROUBLESHOOTING

PROBLEM

Lamp failure indicated when there's no lamp failure.

SOLUTION

The product may have calculated a larger lamp load when the lamp load calculation was performed at the first self-diagnostic function test. To reset the lamp failure status, remove the unit from the wall, disconnect the battery, wait 30 seconds, reconnect the battery, reinstall the unit onto the mounting plate.

The lamp current calculation will be performed on the next self-test/self-diagnostic test.

MAINTENANCE

REMOVAL OF SPLICE BOX COVER

Splice Box Cover can be removed by pressing the snap tabs marked "Press".

BATTERY - The battery supplied in this unit requires no maintenance. It will be periodically tested by the **SELF-TESTING / SELF-DIAGNOSTIC** system according to the requirements of NFPA 101. If battery replacement is required, replace using the BATTERY INSTALLATION procedure.

For the **9W Curve**, the unit will be supplied with a Nickel Metal Hydride (Ni-MH) battery, replace with part number **B350007** only.

For the **16W Curve**, the unit will be supplied with a Lithium Iron Phosphate (LiFePO4) battery, replace with part number **B410001** only. Do not interchange battery types.

Used batteries may not be disposed of in the municipal solid waste stream. Arrangements for recycling batteries can be made by contacting www.call2recycle.org.

INFARED REMOTE TESTING

All Curve Units come furnished with Infrared Remote Capability.

The USER-TEST can be performed up to 20 feet away using the standard "INFRARED REMOTE TESTING TRANSMITTER".

By aiming the TRANSMITTER [FIGURE I] at the Curve, and pushing the "TEST SWITCH" [FIGURE A] at the unit for 1 second, the lamps will illuminate for 30 seconds. If the "STATUS" indicator shows GREEN indicating a fully charged Battery and the Switch is pushed for 4 seconds, the lamps will illuminate for 90 minutes. In either mode, you can cancel the test by pushing and holding either button for 1 second.



Figure I:
Remote Transmitter



EVENLITE

Lives Depend On Us

SAVE THESE INSTRUCTIONS

2575 Metropolitan Drive • Trevose, PA • 19053 U.S.A

Telephone: (215) 244-4204 • Fax: (215) 244-4208