

PROJECT NAME:	APPROVED BY:	
CATALOG NO:	TYPE NO:	

SENTRY - LED Signs DCG Series

Custom Graphics

Architectural quality, open face Sentry Series Die Cast Aluminum sign. Long Life, low energy LED light source illuminates a polycarbonate lens stenciled with your required custom legend.

The open face design allows for any variation of custom wording and the stenciled legend provides for high contrast, legend uniformity, and visibility. Ideal for hospitals, schools, public buildings, or any place requiring special wording signage. A full range of options including battery backup, fire alarm interface, flasher, further enhance the versatility in applications.



Construction

- Maintenance free LED light source with 25+ years life expectancy
- Uniform vivid legend illumination available with Red, Green, Blue or White LED light source
- Silver-White opaque stencil background is standard
- Custom colors are available to order
- Spectrally matched Fluorescent diffuser for superior visual brightness and legend uniformity
- Self-Diagnostic Battery monitoring on all 'EM' models
- Two piece thick wall construction housing from heavy-duty die cast aluminum alloy, removable front face with overlapping light seal
- Fine grain brushed aluminum trim standard. Other finishes available
- Wide selection of standard legends available, custom legends available to order
- Hidden knock out access points and universal pattern
- Low profile universal canopy with cast 3/4" nipple and locking nuts
- Optional recessing frame, polycarbonate face shield with tamper proof access screws, pendant & specialty mounts

Electrical

- High intensity LED array provides exceptional energy efficiency with just 1-watt power consumption for both single and double face AC models.
- Battery backup models consume just 2.5 watts, .77 power factor
- 4 Hour battery backup runtime with Premium long life high temperature fused nickel cadmium battery pack
- 120 or 277 VAC field selectable input with quick install push wire connectors
- Circuitry includes - Zero current LVCO, Brownout sensing & Line-Latch
- Electronic control circuit applies full wave, low ripple current to each LED thereby optimizing life and light output.
- A diagnostic self-compensating constant current charger circuit monitors the condition of the battery pack and indicates via a flashing LED to replace the battery
- Remote capable to power a remote exit only

Certification

- California Energy Commission (CEC) Title 20 Compliant

Warranty

- 5 Year Limited Warranty



Sentry Custom Graphics LED Signs DCG Series

ORDERING GUIDE – DCG

Example: DCG-EM-1-WW-CN-CG-RD-W-SD "Specify Graphics"

Model	No. of Faces	Body and Face Color	Mounting	Graphics/Image	Illuminated Letter Color	Background Color	Options
AC AC Only 120/277 VAC	1 Single Face	AB Brushed Face, Black Body	1B Back Mount, No Canopy	01 X-RAY IN USE <i>See page 3 for more options</i>	RD Red GN Green BL Blue W White C Custom	W White BK Black BL Blue C Custom (specify)	LL High/Low Level Master/Remote (AC and EM models) Remote is 1B mount with recessing frame DL Damp Location F Flash in Emergency Mode (EM models only) FZ F option including Buzzer FA Fire Alarm Interface from 12–24 Volt (AC or DC) Normally Off Fire Alarm Signal (EM models only) FB FA option including Buzzer DK Two Circuit Input, 120 or 277 V (AC models only) SD Self Test / Self Diagnostic (EM Only) P1 1/8" Polycarbonate Shield (includes TP) TP Tamperproof Screws IR Self Test / Self Diagnostic with Infrared Remote Testing (EM only) TLRT Infrared Remote Testing Transmitter RE Recessing Frame
EM Battery Backup	2 Double Face	BB All Black WW All White AA All Brushed Aluminum AW Brushed Face, White Body CC Custom Color	CN Canopy Mounting Kit (Universal End/Ceiling) RE Recessing Frame (Includes 1B Mount) PA 12" Swivel Pendant Mount PB 24" Swivel Pendant Mount PC 36" Swivel Pendant Mount PD 48" Swivel Pendant Mount	C Custom Letter AR Right AL Left CG Specify Required Graphic At End		<i>Notes: Letter and background colors cannot be the same</i>	
DCG							

Fill in fields from categories above and complete type and part

Type Number:

Full Part Number:

NOTE: For signs requiring directional indicators, select C custom letter and specify graphic with chevron direction.

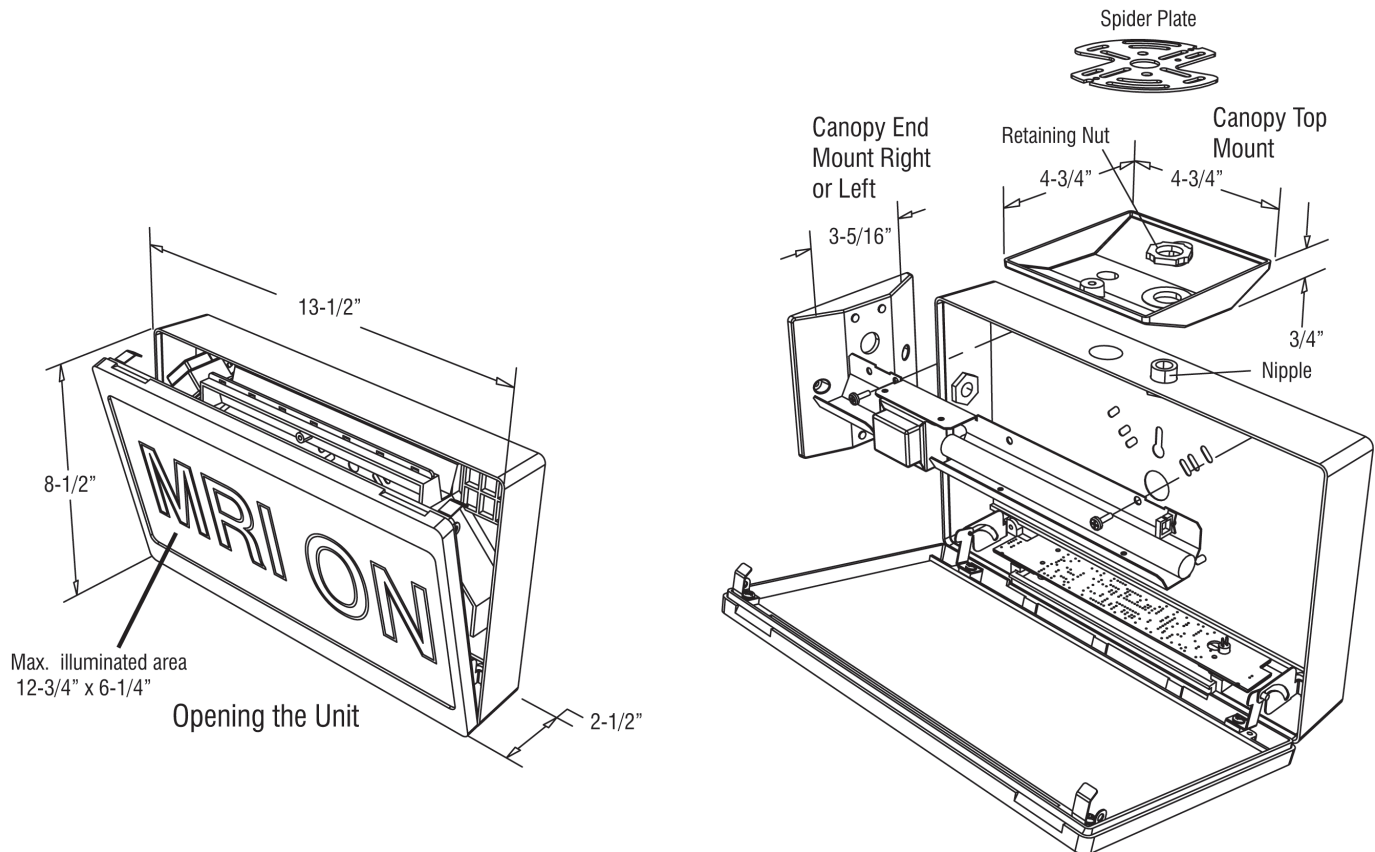

Note: Wire guard available for wall mount units, see data sheet WG-VS
Contact the factory for any required options that are not listed

Top and End Mounting

Sentry Custom Graphics LED Signs DCG Series

NOTE: For signs requiring directional indicators, select C custom letter and specify graphic with chevron direction.

01 	02 	03 	04 	05 
06 	07 	08 	09 	10 
11 	12 	13 	14 	15 
16 	17 	18 	19 	20 
21 	22 	23 	24 	25 
26 	27 	28 	29 	30 
31 	32 	33 		

